

# PHANTOM

## INSTALLATION MANUAL





**PLANET**  
LIGHTING

## 1.0 INTRODUCTION

This installation and instruction manual describes how to install, maintain and operate the Planet Model 'Phantom' examination/Minor procedure light. Prior to installation carefully read through all the instructions enclosed in this manual.

If there are any concerns or you do not understand, please contact customer service at Planet Lighting.



### WARNING

Only qualified electricians can install the Planet model 'Phantom' light. It is to be direct wired only. Installation performed by unauthorised personnel could result in personal injury and or equipment damage. Under no circumstances should any modifications or adjustments, other than those detailed under the Maintenance section, be made to the Planet Model Phantom.

The Phantom Light Complies with AS/NZ standards 3200-2-41 (IEC 60601-2-41)

## 2.0 PRODUCT INFORMATION

The Planet Phantom is a state of the art Minor procedure/examination light which utilises cutting edge Solid State Lighting technology. Designed and manufactured in Australia by Planet Lighting (established 1911) an R&D driven, exporting designer and manufacturer with over 10 years experience in the design, manufacture and supply of Solid State Lighting devices worldwide.

The Planet Phantom provides an improved working environment, significantly reducing on-going maintenance, with low operational costs and offers a "greener" alternative to similar products.

The Planet model Phantom allows the accurate positioning of the lamp head above any work surface. It is designed to be mounted on a wall or ceiling and be pulled down from above when required, remaining there until re - positioned.

At Planet we take great pride in the design and production of our lights and we are sure you will derive satisfaction from owning and using our products. When installed and maintained in accordance with the instructions contained in this service leaflet, this product will provide many years of trouble free operation.

Should you have any enquiry, comment or special lighting need we would like to hear from you. We back our products with pride, service and a five year warranty.

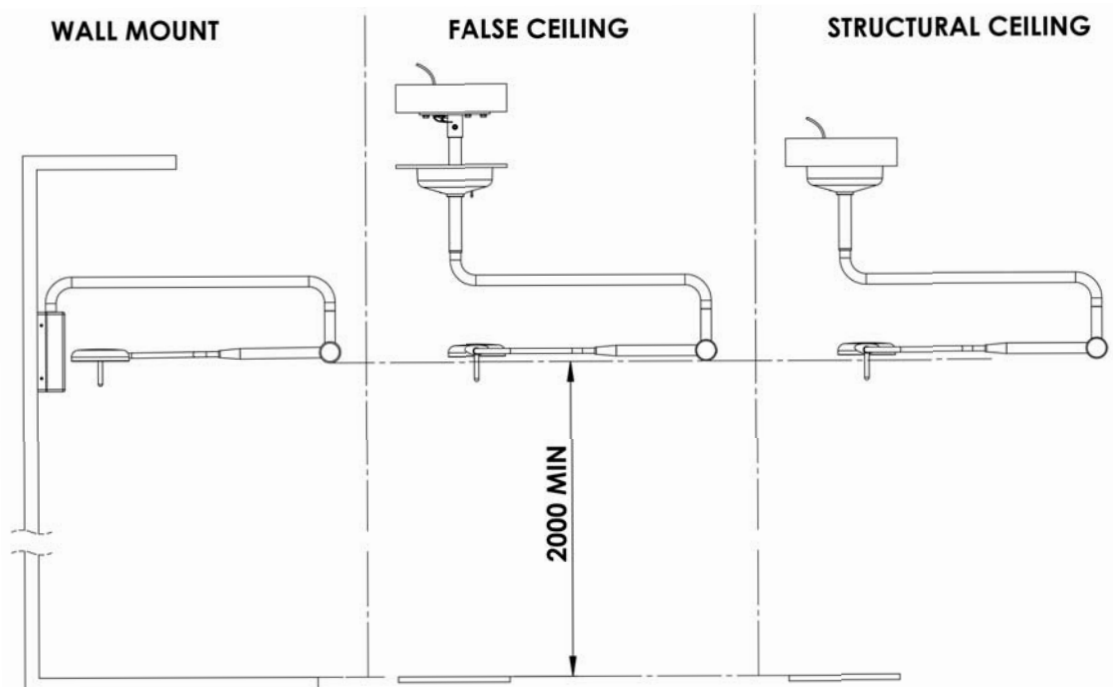

Fig 1.0

## 2.1.0 ENVIRONMENTAL CONSIDERATIONS

### 2.1.1 PACKAGING

Confirm boxes containing a complete Phantom lamp with Installation and user's manual have arrived, and there is no obvious transport damage.

### 2.1.2 TRANSPORT

Transport to be carried out by road, while maintaining the following environmental conditions.

Temperature: -15/+60 degrees Celsius

Humidity : 10/75%

Atmospheric pressure(h/Pa) 500/1060

### 2.1.3 STORAGE

The devices packaged must be stored (warehoused) in a dry place and as per the same environmental conditions mentioned above.

## 2.2.0 DISPOSAL AND RECYCLING INFORMATION

The Phantom light has been designed, taking into account what the manufacturing components are made out of. This is to ensure when it reaches its end of life, the disposal method with the lowest/least negative impact, on human health and the environment is selected.

Unlike the sources of traditional light, LED's do not contain mercury, toxic gases, filaments or fragile parts. Due to the fixture being over 95% recyclable and there being no Bulbs/ Globe changing during the ULED life of 50,000+ hours, your environmental footprint will be significantly reduced.

When your Phantom light reaches its end of life, contact Planet lighting or our local agents to learn about recycling options. The Phantom light must be disposed of properly according to local laws and regulations.

## 3.0 PLANNING

The Building Facility mechanical and electrical installation works are the responsibility of the purchaser.

Prior to installing the Planet Model 'Phantom' Ceiling and Wall mounts the following items should be checked and confirmed.

### 3.1.0 ARCHITECTURAL CONSIDERATIONS

3.1.1 Ensure appropriate mounting structure behind the wall/ceiling

3.1.2 For structural loadings and approx product weights refer to Fig 2.0 for Ceiling, and Fig 15.0 for Wall mounted.

3.1.3 To confirm ceiling/wall height measurements at the appropriate nominal recommended height from the floor refer Fig 1.0

### 3.2.0 ELECTRICAL CONSIDERATIONS

3.2.1 The Planet Model 'Phantom' wall and ceiling mount are designed to be direct wired only

3.2.2 240V AC supply is available at the connection points

 PLANET LIGHTING	Voltage:	240v
	Input Current:	0.12A
	Frequency:	50Hz
	Classification:	Class 1
	Model:	PHANTOM - Ceiling
<a href="http://www.planetlighting.com">www.planetlighting.com</a>		

 PLANET LIGHTING	Voltage:	240v
	Input Current:	0.12A
	Frequency:	50Hz
	Classification:	Class 1
	Model:	PHANTOM - Wall
<a href="http://www.planetlighting.com">www.planetlighting.com</a>		

## 4.0 INSTALLATION

The Planet Model Phantom arm is designed to be mounted above the immediate work area. Standard mounting fixtures for Planet Model Phantom are: Ceiling Mount & Wall Mount (specialised mountings are available on application). In all cases the suggested mounting height (measured at swivel head) is two metres from floor level, as seen in Fig 1.0.



PLANET  
LIGHTING





#### 4.1.2 DETERMINE THE CEILING TUBE LENGTH

H(mm)	L(mm)
2550	110
2600	160
2650	210
2700	260
2750	310
2800	360
2850	410
2900	460
2950	510
3000	560
3050	610
3100	660
3150	710
3200	760
3250	810
3300	860
3330	910

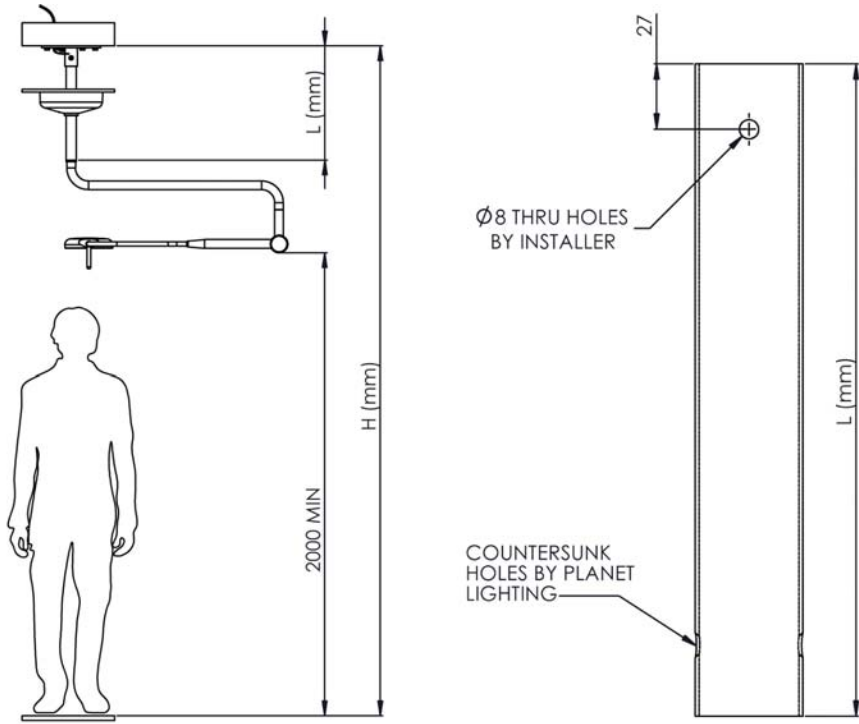

Fig. 4.0

#### 4.1.3 CUT CEILING TUBE TO LENGTH

**⚠ WARNING**

Do not cut tube end with countersunk holes

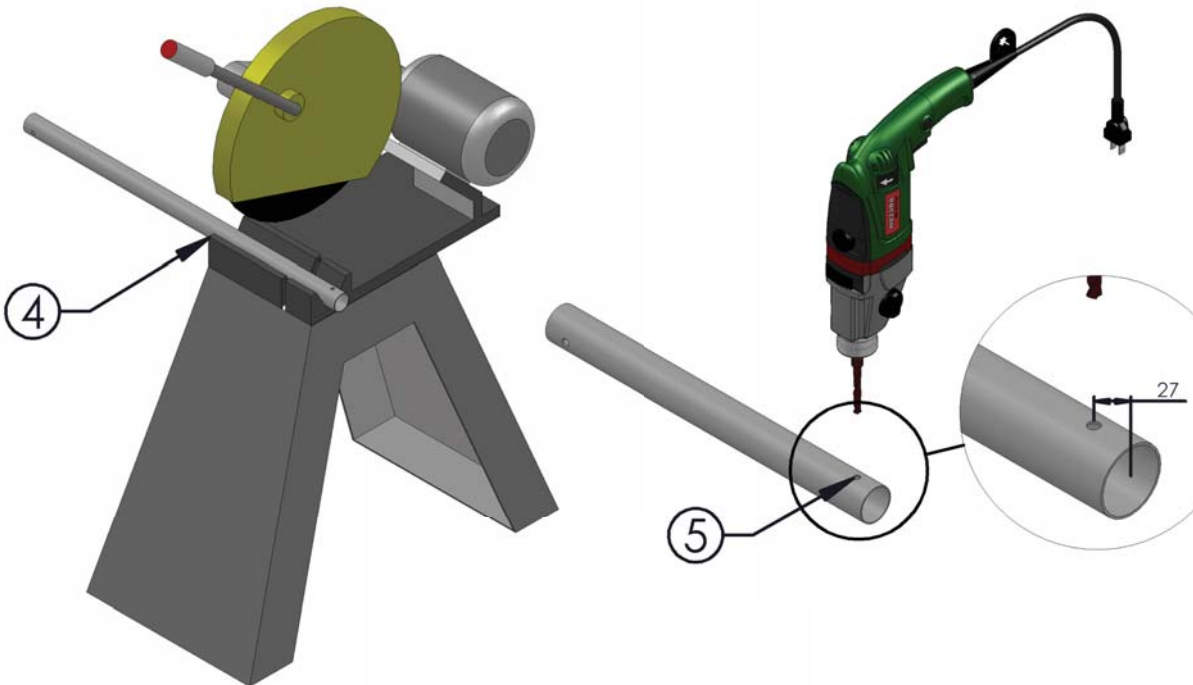

Fig. 5.0

4. Cut ceiling tube to length, based on the table in Fig. 4.0

5. Measure, and drill through hole for the locking bolt, as shown in Fig. 5.0.



**PLANET**  
LIGHTING



#### 4.1.4 PRE CEILING FIT OUT



Fig. 6.0

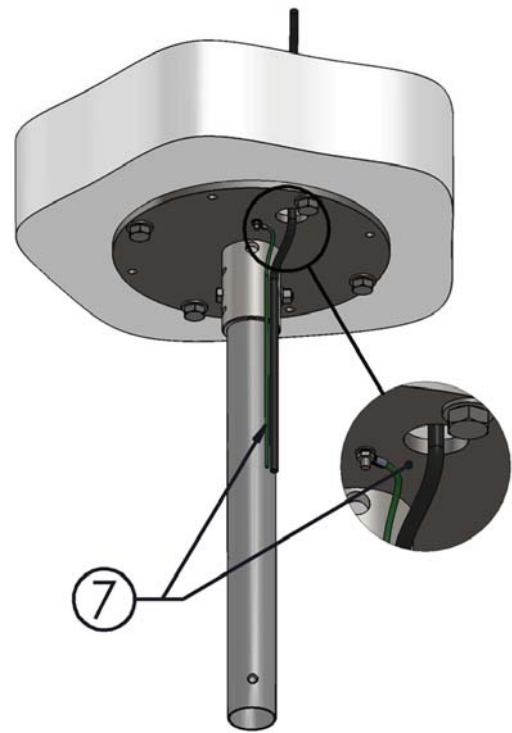

Fig. 7.0

6. Assemble ceiling tube to ceiling plate, with the locking bolt and nut, as shown in Fig. 6.0

7. Reticulate 240v power to the power supply mounting location in accordance with local standards and regulations. Attach the mounting plate earth, and reticulate power to the mounting location, as shown in Fig 7.0.

#### 4.1.5 RETICULATE POWER TO CEILING LEVEL



Fig. 8.0

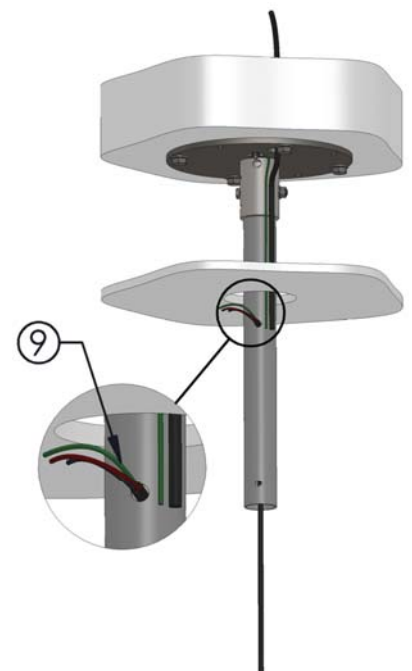

Fig. 9.0

8. Drill cable access hole in the ceiling tube at the sub-ceiling level, as shown in Fig. 8.0. Take care to remove power cords from the drilling area, before drilling.

9. Complete the reticulation of 24v power to the power supply mounting location as shown in Fig. 9.0.

#### 4.1.6 POSITION POWER SUPPLY AND TIGHTEN ONTO THE CEILING TUBE

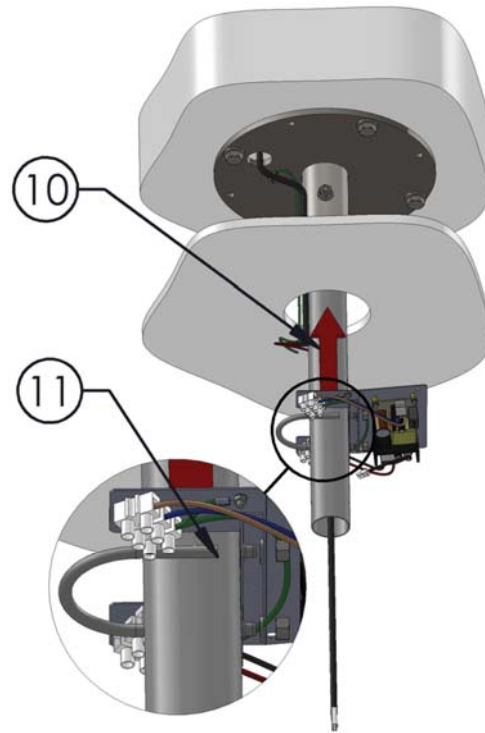

Fig. 10.0

10. Slide power supply into mounting position, as close to the ceiling as possible, as shown in Fig. 10.0.

11. Using the u-bolt, nuts and washers supplied, attach the power supply assembly to the ceiling tube, as shown in Fig. 10.0.

#### 4.1.7 CONNECT POWER

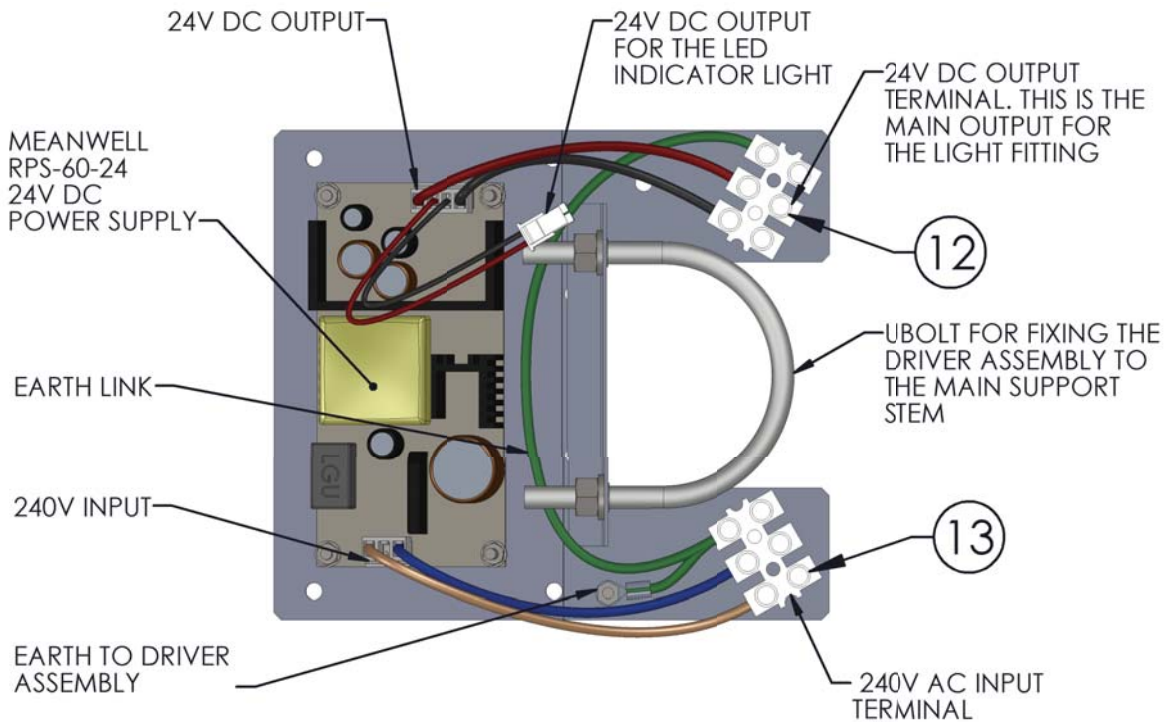

Fig. 11.0

12. Connect the 24v power feed, and earth for the light fitting into the terminal, shown in Fig. 11.0

13. Connect the 240v AC input, and earth into the terminal, as shown in Fig. 11.0.



#### 4.1.8 ATTACH CEILING COVER

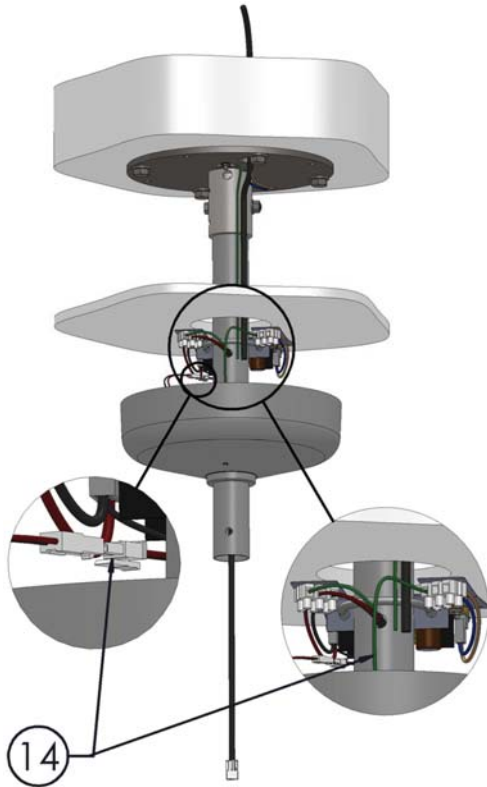

Fig. 12.0

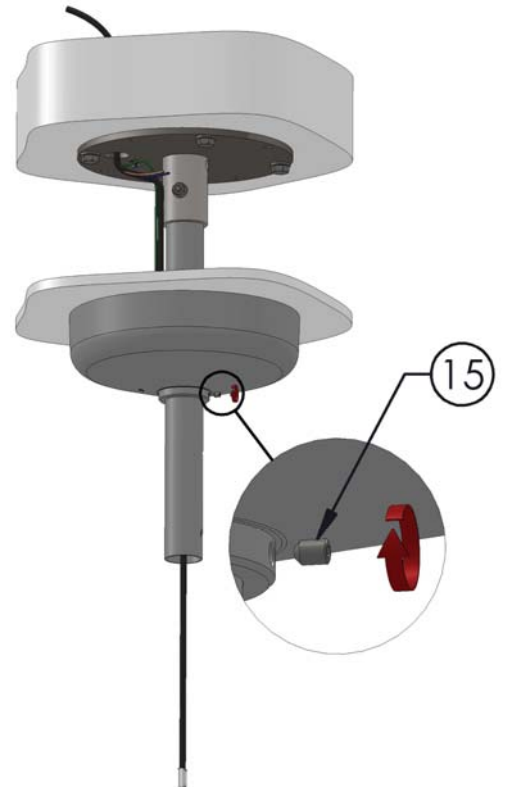

Fig. 13.0

14. Move ceiling cover into place, and connect the 24v DC output for the LED indicator light.

15. Push the ceiling cover up against the ceiling and tighten the grub screw to lock it in place, as shown in Fig.13.0.

#### 4.1.9 ATTACH LIGHT FITTING TO CEILING TUBE

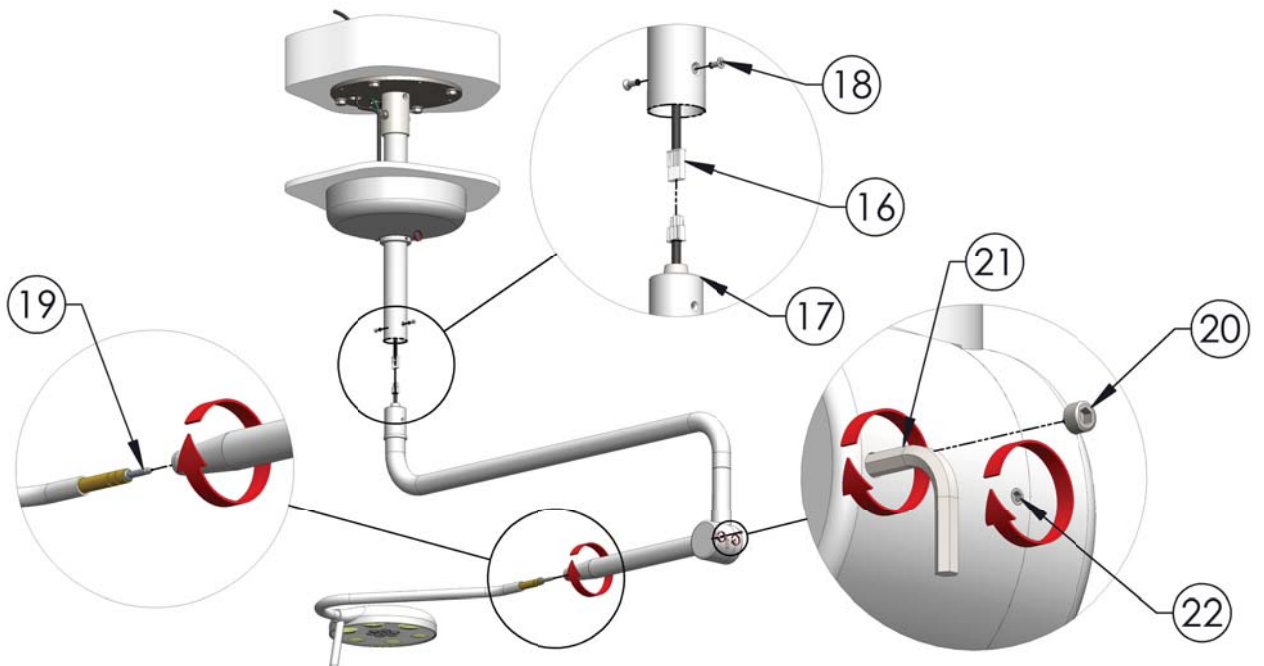

Fig. 14.0

16. Lift Phantom arm into place, and engage the 24v plugs as shown in Fig. 14.0.

17. Insert the arm bearing into the ceiling tube (taking care to align the threaded holes on the bearing sheath with the countersunk holes on the ceiling tube), as shown in Fig. 14.0.

18. Insert the countersunk head set screws as shown in Fig. 14.0.

19. Optional - remove or replace the lamp head - twist the conical end of the arm and pull the head and s-bend section, as shown in Fig.14.0.



## MAINTENANCE ONLY

20. Unscrew the end cap for access to the spring balance adjustment, as shown in Fig. 14.0.

21. Adjust the spring balance: using a 4mm allen key, adjust the screw inside the knuckle. Clockwise/ Tightening the screw will cause heavier engagement of the spring - this will improve 'head droop'. Anticlockwise/loosening the spring balance will fix a 'rising head' issue, as shown in Fig. 14.0.

22. Friction adjustment: Clockwise/tightening this screw will apply more friction to the arm mechanisms. The arm will require more force to move, however will not continue to move with moment. This should be set to the staff preference, as shown in Fig 14.0.

## 4.2 WALL MOUNT

### STRUCTURAL LOADS - WALL MOUNT:

The structural integrity of the mounting surface is the responsibility of the installer. Structural loads are as follows:

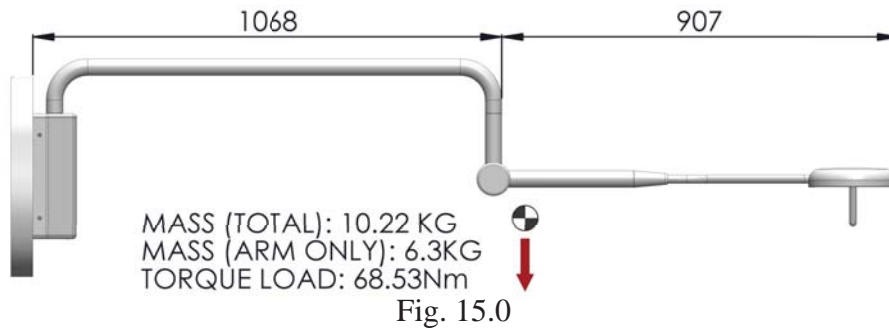

### 4.2.1 MARK UP AND MOUNT WALL UNIT

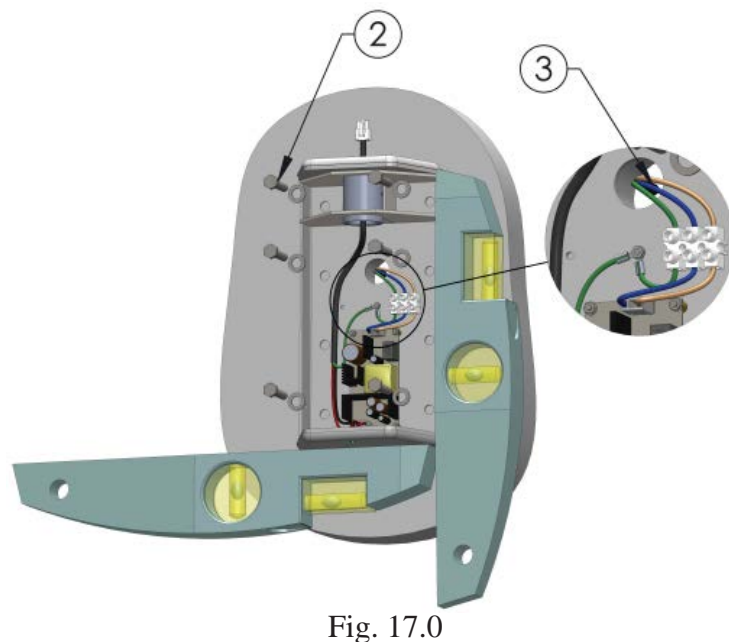
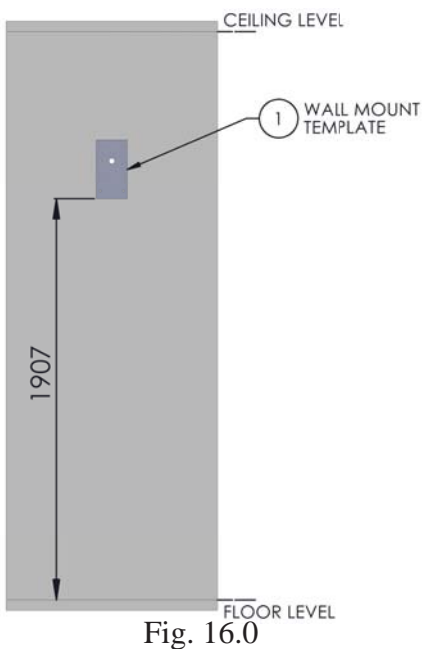

1. Use the wall mount template from the centre page of this document. Measure up 1907mm from the floor, and align the bottom of the wall mount template with this mark. Position and fix the template into position, ensuring that both edges are level to the vertical and horizontal, as shown in

Fig. 16.0. Use the template to mark hole positions for cable access and mounting.

2. Installer to select suitable fixings, and fix the wall unit to the structurally sound wall, ensuring that the unit is level on all edges Fig. 17.0.

3. Reticulate the 240v power to the power supply location, and connect to the fitting at the terminal block as shown in Fig. 17.0.





PLANET  
LIGHTING

#### 4.2.3 MOUNT FITTING

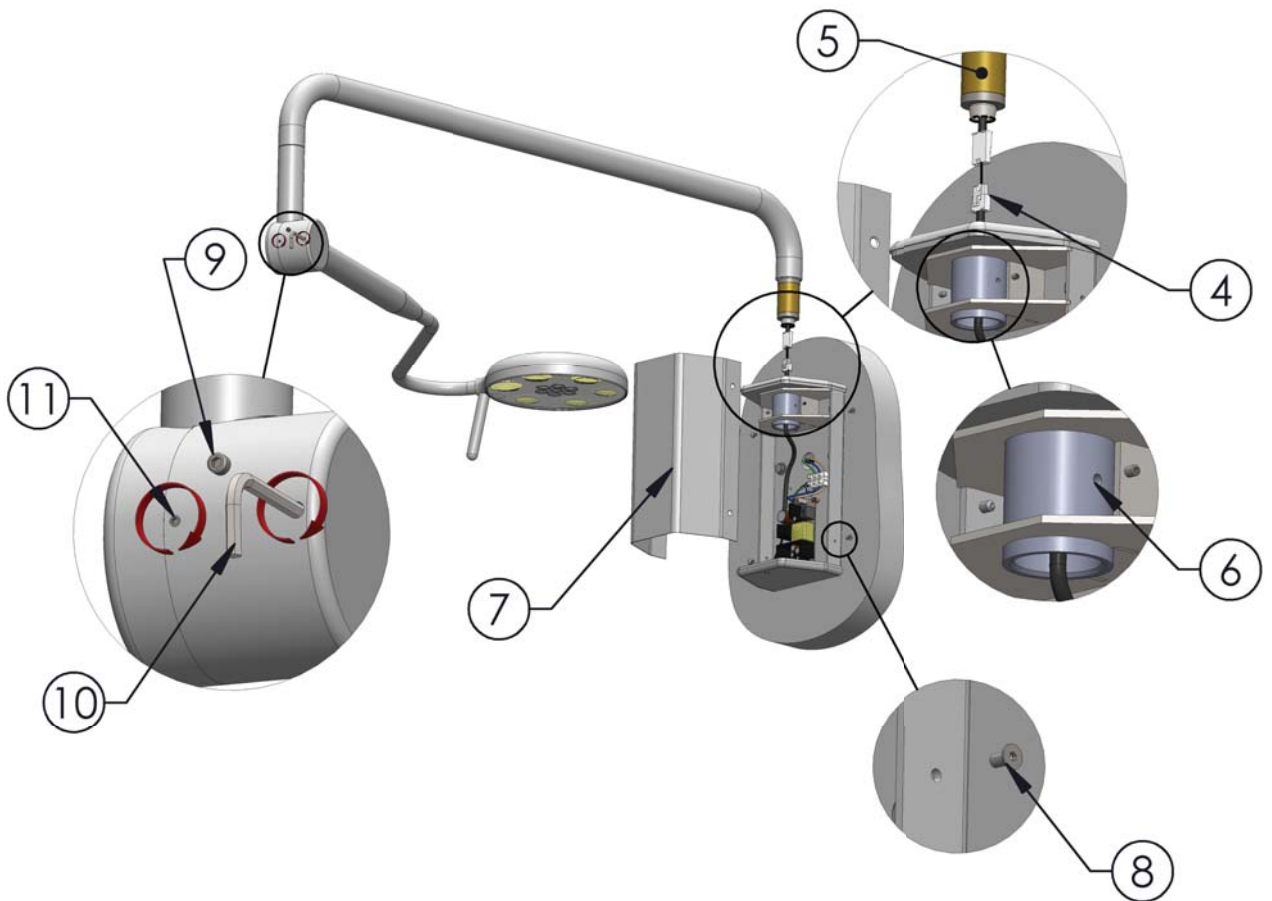

Fig. 18.0

4. Lift Phantom arm into place, and engage the 24v plugs as shown in Fig. 18.0.
5. Insert the arm bearing into the wall unit (taking care to align the threaded holes on the arm side bearing sheath with the corresponding holes on the bearing sheath on the wall unit, as shown in Fig. 18.0).
6. Insert and tighten the two grub screws to complete the fixing of the arm to the wall unit as shown in Fig. 18.0.
7. Replace the wall unit cover as shown in Fig. 18.0.
8. Fix in the place with the countersunk screws provided, as shown in Fig. 18.0.

#### MAINTENANCE ONLY

9. Unscrew the end cap for access to the spring balance adjustment, as shown in Fig. 18.0.
10. Adjust the spring balance: using a 4mm allen key, adjust the screw inside the knuckle. Clockwise/ Tightening the screw will cause heavier engagement of the spring - this will improve 'head droop'. Anticlockwise/loosening the spring balance will fix a 'rising head' issue, as shown in Fig 18.0.
11. Friction adjustment: Clockwise/tightening this screw will apply more friction to the arm mechanisms, as shown in Fig. 18.0. The arm will require more force to move, however will not continue to move with moment. This should be set to the staff preference.

## 5.0 MAINTENANCE

### Cleaning and disinfection Protocol

 WARNING

- Turn off the light before commencing any cleaning.
- Let the light cool down. Disinfect and clean the light and body (including any cables) only when it is cold.
- Make sure that excess water/cleaning agent has been removed from cleaning cloth before commencing.
- Use a damp, NOT wet Cloth.
- Use alcohol/detergent having medium alkaline level but no active chlorine.

 ATTENTION : Do not use abrasive products, petrol, paint thinners, alkaline detergent, acidic cleaning agents or aldehydes. Make sure the proportions of the detergents/cleaning agents are accurate based on manufacturers Instructions.

 WARNING The disinfectants/cleaning agents may contain substances harmful to health: use disinfectants only recommended by your health authorities and follow the manufacturer's user instruction carefully.



**PLANET**  
LIGHTING



**Customer Service can be contacted on the phone number below Mon - Friday 9 am - 5 pm**



**Made in Australia Exported to the World**

Tamarind Drive Bellingen NSW 2454 Australia

Phone + 61 (0)2 6659 5600  
info@planetlighting.com

Fax + 61 (0)2 66552121  
www.planetlighting.com



PLANET  
LIGHTING

