

**INSTALLATION / WARRANTY INSTRUCTIONS**
**PRODUCT BRAND:** PIERLITE  
**PRODUCT NAME:** Vandalex Adverse Washbay Weatherproof Batten

Issue Date: 18/07/2023

Please read these installation instructions carefully before installing or maintaining this equipment. The product is designed for installation and maintenance in accordance with relevant Australian standards (AS/NZ3000), by an authorised and licensed electrician. The installation instructions were correct at the time of print. To reflect changes in technology and Australian and New Zealand standards; Pierlite reserves the right to amend the instructions without notice. Updated guidelines can be found on relevant brand website.

**1. PRODUCT SPECIFICATION:**

Luminaire Name	Vandalux Chemical Washbay			
SKU	VXOLS2DG	VXOLS2DGM2	VXOLS4DG	VXOLS4DGM2
Diffuser Type:	Opal	Opal	Opal	Opal
Length:	2ft		4ft	
Type:	Mains only	Mains with Emergency	Mains only	Mains with Emergency
Optic	Symmetrical			
Type of Protection	Class I luminaire			
Ingress Protection	IP66			
Impact Rating	IK10			
Nominal Voltage	220 - 277v			
Nominal Frequency	50 / 60Hz			
Power Factor	>0.8 to >9			
Number of Wattages Per Fitting	4		5	
Wattage	16W / 20W / 28W / 33W		23W / 32W / 38W / 55W / 65W	
Lumen Output (exit lumens)	1396lm / 1568lm / 1817lm / 1935lm	1396lm / 1568lm / 1817lm / 1935lm	2262lm / 3596lm / 4092lm / 5047lm / 5628lm	2262lm / 3596lm / 4092lm / 5047lm / 5628lm
Efficacy	75lmW / 69lmW / 58lmW / 53lmW	75lmW / 69lmW / 58lmW / 53lmW	89lmW / 105lmW / 99lmW / 89lmW / 84lmW	89lmW / 105lmW / 99lmW / 89lmW / 84lmW
Line Current	L-N 4KA, L-E: 4KA, N-E: 4KA			
Inrush Current	0.09A / 0.1A / 0.14A / 0.15A	0.11A / 0.12A / 0.16A / 0.18A	0.112A / 0.153A / 0.173A / 0.232A / 0.274A	0.13A / 0.18A / 0.2A / 0.25A / 0.3A
Earth Leakage	Cold start 10A(twidth=46µs measured at 50% Ipeak) at 230VAC			
Surge Protection Rating	0.4mA			
Ambient Temperature	-25°C to +50°C (63W@45°C)			
LED Lifetime	L70 B10 72,000hours			
Colour Temperature	7892K			
Colour Rendering Index (CRI)	CRI -33			
Colour Wavelength	527nm			
LED Control Gear	Integral European driver			
Control System:	DALI2 / Lumen select			
DALI Addresses Required	1	2 (mains + emergency)	1	2 (mains + emergency)
Emergency Wattage	N/A	3W	N/A	5w
Emergency Lumen Output	N/A	386lm	N/A	817lm
Emergency Classification	N/A	C0/C180: D50 & C90/C270 : D32	N/A	C0/C180: D100 & C90/C270 : D63
Emergency Battery Technology	N/A	Lithium Iron Phosphate battery	N/A	Lithium Iron Phosphate battery
Diffuser Material	Polycarbonate			
Housing Material and Finish	Chromated LM6 (low copper content) Aluminium with RAL9007 powder coating			
Electrical Connection	Direct to 6.0mm <sup>2</sup> terminal block			
Cable Entry	2x20mm cable entry - 1 on either end & 1x drill points (up to 25mm) through back of fitting			
Installation Type	Ceiling or Wall. Optional accessories available			
Diffuser Screw Type:	5mm Allen key			
Dimensions (LxWxH)	700mm x 138mm 114mm		131mm x 138mm 114mm	
Net Weight of Luminaire	4kg		8kg	
Warranty Luminaire	5 years			
Warranty Battery	N/A	4 years	N/A	4 years
Suitability	Outdoor and Indoor			
Suitable for Rough Service	Yes			

### 1.A. LUMEN SELECT METHODOLOGY

Fitting Type	Diffuser	Wattage	Fitting Size	Control gear	Colour Temperature	Emergency	Rail Spec
VX = Vandalux	O = Opal	LS = Multi Wattage - Factory default = 53W	2 = 2 foot (700mm) 4 = 4 foot (1310mm)	D= DALI	g = green	M2 = Maintained 2hr	PB = Rail/Heavy industrial Spec

### 2. CONSUMABLES

Description	QTY Required Per Fitting	Brand	Component Part Number	Dimensions (LxWxH) mm
2 amp fuse	1	Glass fuse	TDC180-2A	20 x 5 x 5
2-hour duration 6.4V 3.2AH 2 Cell Side by side pack	1	Pierlite	BATPK3200/2L21	70 x 53 x 31
4-hour duration 6.4V 6.0AH 4 Cell Side by side pack	1	Pierlite	BATPK6000/4L22	140 x 53 x 31

### 3. SERVICE & OPERATION (EMERGENCY VERSION)

Normal Operation: Maintained Emergency Operation.

Battery: Sealed Lithium Iron Phosphate (LiFePO4) rechargeable battery pack. As per AS/NZS 2293, it is required that the battery pack is discharged and recharged at least once every 6 months.

In case of a replacement, same brand and type of battery pack must be used. Allow 24 hours charging time before carrying out any discharge tests.

Charge Duration: 16 Hours

Discharge Duration: M2 = 2 Hours for standard emergency or M4 = 4 hours for rail & heavy industry emergency specification (Initial Test)

Test Switch: If manual test switch pressed, the fixture will operate from its battery supply. Please ensure battery plug is connected to the inverter battery terminal.

**Please note: All maintenance, such as battery change on this luminaire is to be changed by qualified personnel only. De-energise all supplies before maintenance.**

#### Test Operation:

**While connecting DALI bus:**

A 5 second Function test is carried out at 28 days interval.

A 90-minute Duration test is carried out automatically at 26 weeks interval.

**Self-Test Mode:** The Emergency conversion module will run in self-test mode if it is not connected to DALI.

In this mode, a Commissioning Test will be run after 48 hours of continuous power. This consists of a Duration Test to test the system and will run for the full 120 minutes. The results will be displayed on the status indicator for 7 days after this test completes. From that point forward the unit will run a 5 second function test every 28 days and a 90-minute Duration Test every 26 weeks. If the battery is replaced, then the unit will automatically run another Commissioning Test after 48 hours.

Indicator Color Instruction		
Indicator Colour	Status	Meaning
Green Solid	Device ok	all OK, AC power is present, battery is connected & charging
Green fast flash (0.1s on, 0.1s off)	Function test in progress	AC power is present, functional test in progress
Green slow flash (1s on, 1s off)	Duration test in progress	AC power is present, discharge test in progress
Green very slow flash (4s on, 1s off)	Automatic duration test passed	AC power is present, automatic discharge test has completed within the last 7 days and was ok
Red Solid	Emergency LED Fault	Emergency LED is an open circuit, short circuit or has otherwise failed in some way. fault can indicate the live status or the result of a test
Red fast flash (0.1s on, 0.1s off)	LED Driver fault LED	Unit unable to deliver current to emergency LED. fault can indicate the live status or the result of a test
Red slow flash (1s on, 1s off)	Battery fault	Battery failure (battery failed the duration or functional test, battery appears to be defective, battery has incorrect voltage)
Red/green alternating	Identification mode	The unit is in unit identification mode
Red/Green Off	No power available	AC power is lost, unit in emergency mode





### 4. LUMEN SELECT TABLE (contractor selectable output)

Pierlite's lumen select products allows all licensed electricians to purchase one luminaire that can be set as multiple fixed wattages/ fixed lumen outputs. By offering this capability within one fitting it provides the following benefits

- One fitting multiple fixed outputs for versatility onsite
- Less stocked items
- Easy to change settings
- IES files available for all available for wattages shown in the above table
- No control system or software required to change fixed output

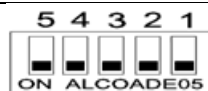
The lumen output can be altered by changing the driver dip switches from the factory default setting to the driver milli-amps as specified in the table. Dip switches are located next to suspension hook of the Highway.

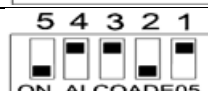
**Note:** Make sure to disconnect power before changing a DIP switch on the luminaries. Setting the DIP switches according to the above ONLY. All other settings may affect the luminaries' performance. After setting, secure the silicon cover over the DIP switches.

System Wattage (W) 2ft fitting	System Wattage (W) 4ft fitting	Driver Settings (mA)	Driver Dip Switch Settings
33W	63W	1400	
28W	53W (factory default setting)	1150	
20W	37W	850	
16W	30W	700	
N/A	22W	500	

**5. DALI CONTROL GEAR:** The LED driver and emergency control gear are both controllable through the DALI control system with an emergency monitoring system. A DALI connection is not required in a non-systemized electrical system.

**Note:** When designing the DALI system please refer to the table below for the number of DALI addresses.

Control gear	Function	Number of Addresses
LED Driver	Dimming, on/off & feedback	1
Emergency Inverter	Testing & Reporting	1

6. LINE DIAGRAMS

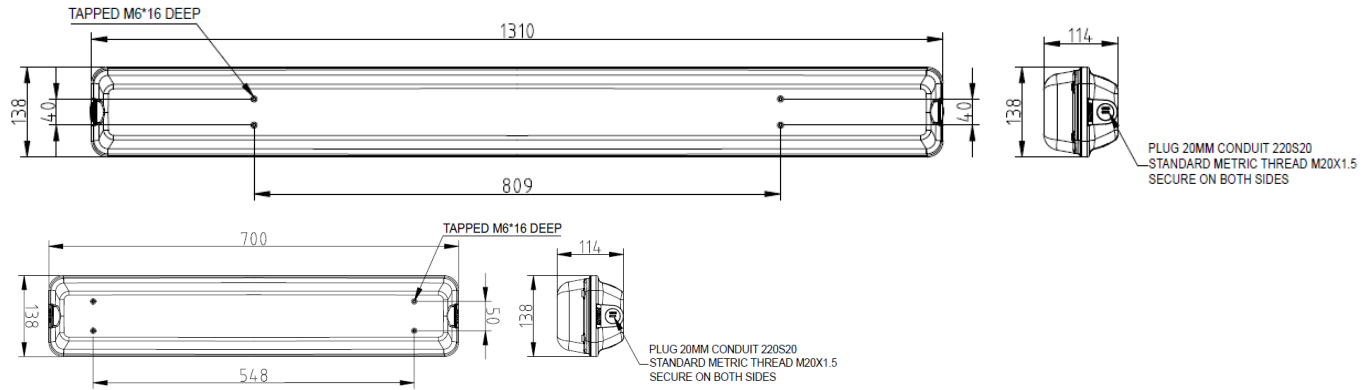

7. **INSTALLATION / GENERAL:** Installation of the product is to be completed by an authorized and licensed electrician, in accordance with these instructions, relevant Australia standards and local regulations (where applicable). Termination of product wiring, together with the installation of the product must be in a manner and orientation that maintains the integrity of the designated IP rating of the product for electronic control equipment (when supplied) DO NOT MEGGER between A and N.

Installation:

Ensure the appropriate bracket has been ordered for your installation type. Refer to the bracket installation instructions for further information.

- a) Isolate the supply circuit as per the Australian standard and your SWMS.
- b) Remove both the diffuser and the gear tray using a 5mm hex head and place in a safe location to ensure the product does not get damaged while the housing is being installed.
- c) Install the housing with the selected bracket system.
- d) Suspend the gear tray from the lanyards
- e) Connect the supply wires to the supplied 6mm<sup>2</sup> terminal block. Ensure sure all connections and cabling complies to AS3000.  
**Note:** Ensure the correct wires go to the correct terminals as per below

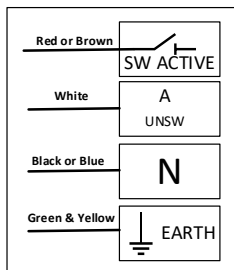

Emergency & Mains Wiring Connections

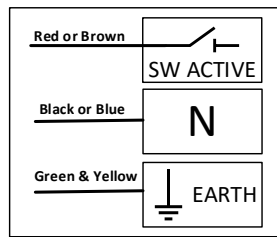

Mains Only Wiring connections.

- f) Select the wattage/lumen output by changing the dip switches on the LED driver, please refer to section 12 of this installation sheet. **Note:** 55W/6153lm is the factory default for this fitting.
- g) Secure the gear tray to the luminaire body ensuring all cables are clear from pinching or possible damage.
- h) Tighten the screws securing the gear tray to a maximum of 4Nm
- i) Installation of the diffuser, lightly screw the supplied hex head screws into the 6 holes around the diffuser. Place diffuser to the body and tighten screws to a maximum of 4Nm.
- j) Ensure the IP rating of the installation is equal to that of the tested IP rating of the fitting. **Note:** the IP rating of the fitting is IP66.
- k) Test fitting as per the relevant Australian standard and as per your SWMS.

Cable Entry,

Cable entries can be made through the threaded 20mm entries on either end of the housing or through the back of the housings in the three raised mounds. The following modifications can be made.

- The threaded cable entries can be drilled and tapped to a maximum of 25mm
- For the 2ft housing there is one mound that can be drilled to a maximum of up to 32mm
- For the 4ft housing there is 3 raised mounds that can be drilled to a maximum of up to 32mm

Ensure the IP rating of the installation is equal to that of the tested IP rating of the fitting. **Note:** the IP rating of the fitting is IP66.



**IMPORTANT** - the product must be maintained and operated in accordance with the manufacturer's instructions, failure to do so may damage the product and services. It is strongly recommended that this important note be communicated to the owner and or operator of the installation at the time of site commissioning. Good practice does not recommend the 24/7 use of products without the application of suitable switch cycle intervals. Furthermore, with the omission of nominated survival curves and or recommended operating hours, product design expectations provide for a continual daily usage of 6 hours for residential applications and a continual daily usage of 12 hours for commercial and industrial applications. All products must be thoroughly cleaned on a regular basis at intervals that reflect in the installation environment, ensuring the optical performance, together with the electrical, mechanical, and structural integrity as designed, is maintained throughout the service life of the product.

**APPROVALS:** The RCM marking of this product applies to AS/NZS CISPR15 (EMC) "Limits and methods of measurement of radio disturbance characteristics of electrical lighting and similar equipment". This product is designed to conform to AS/NZS60598 "Luminaires, general requirements and tests".



**STORAGE:** Prior to installation products are to be stored in cool and dry conditions.

**APPLICATION:** The installation application and orientation of the product is designed in accordance with the nominated product IP rating, class designation and these installation installations. Installation environments outside these conditions are not recommended.

**MAINTENANCE:**

- (a) The supply must be isolated before opening or accessing the luminaire. Product maintenance is IMPORTANT and is critical to the products designed performance. The product is to be maintained in accordance with the manufacturer's instructions. For the latest product maintenance guides please go to relevant brand web site. Pierlite is not responsible for any product not maintained in accordance with the recommended procedure or intervals.
- (b) **Lamps (where provided):** The product is designed with the supplied (LEDs) / LAMP/s and it is strongly recommended that any LAMP / (LEDs) changes (if any) be made in accordance with the type, colour and brand supplied. For recommended LAMP / LED maintenance or operating guides (inclusive of recommended product switch cycles and mandatory run-in procedures for HID and Fluorescent lamps when used with dimming circuits), Pierlite recommends the application of the lamp manufacturer's operating guidelines, which can be found on manufacturer's website. Pierlite is not responsible for the product performance of alternative lamp/s used. As a member of FluroCycle, we encourage recycling of lamps and components.
- (c) **Battery (where provided):** The battery is designed with a rated average battery design life in standby mode, and is supported with a standard warranty (refer to product specifications for details); conditional of the product being maintained and operated in accordance with the manufacturer's guidelines and tested in accordance with AS/NZS2293. For guidelines see product installation instructions or visit the relevant brand web site.
- (d) **For products supplied with glass visors or covers,** do not operate the product with a damaged visor or cover; it is recommended the product be turned off, area surrounding the product vacated, and the damaged glass replaced by a professional installer immediately.

(e) **Cables or chords**, If Any external cable or cord of the X or Y type luminaire is damaged, it shall be replaced by a qualified person or manufactures service agent. For Z type attachments to luminaire, cord cannot be replaced if damaged, the luminaire shall be removed from service.

Flex cord types

- X: A specially prepared flexible cable or cord, may also include a part of the luminaire and only available from manufacture.
- Y: Attachment may be used either with ordinary or special flexible cable or cord.
- Z: Attachment of cable or cord that cannot be replaced without damage to luminaire

**WARRANTY INSTRUCTIONS:** For the purpose of warranty claims (if any) the following instructions apply:

**Warranty period** - The above components are provided with a warranty (refer to product specifications for details) against manufacturing defects or failure to perform to specifications for products installed by an authorised installer in accordance with the manufacturer's installation instructions and which have not been subject to incorrect operation or maintenance, unauthorised modification or damage arising from any intervening cause.

**Warranty reference** - The warranty reference date commences from the date of purchase.

**Warranty point of contact** – Pierlite, 96 Gow Street Padstow NSW 2211, phone T 1300 799 300 contact – Pierlite After Sales Support.

**Warranty claim procedure** – For the purpose of making a claim the customer must:

1. Contact the "point of contact" above and upon provision of proof of purchase the customer will receive a goods return advice (GRA) number.

2. At the customer's expense, collect and return the goods to the "point of contact" with the issued GRA number.

3. Upon receipt of the goods, Pierlite will review the claim and if found to be accepted, Pierlite will return a replacement product to the customer to install at the customer's expense. Alternatively, if the claim is rejected, the customer may request the return of the goods at their expense.

**Consumer Contracts** - The benefits to the customer given by the Pierlite warranty are in addition to other rights and remedies of the customer if the goods are the subject of a Consumer Contract under the Australian Consumer Law. In that event the following statement is required to be brought to the Consumer's attention: - *Our goods come with guarantees that cannot be excluded under the Australian Consumer Law. You are entitled to a replacement or refund for a major failure and for compensation for any other reasonably foreseeable loss or damage. You are also entitled to have the goods repaired or replaced if the goods fail to be of acceptable quality and the failure does not amount to a major failure.*

**Limitation of Liability** – if the goods are not purchased by the customer under a Consumer Contract within the Australian Consumer Law then but not otherwise:- (a) the Company is not liable in tort for any loss or damage suffered by the customer or by any third party; and (b) in no circumstances is Pierlite liable to the customer or to any third party for any loss of profits, loss of anticipated savings, economic loss or interruption of business or for any indirect or consequential loss (Consequential Loss).

**Terms of Sale** – these warranty provisions are in substitution for any inconsistent provisions in the Pierlite Terms and Conditions of Sale in so far as they apply to the warranty components.