

## INSTALLATION / WARRANTY INSTRUCTIONS

### PRODUCT BRAND

- PIERLITE

### PRODUCT NAME / CODES

- BWP ECO LED Weatherproof Batten Gen 2  
BWPECO202ECS, BWPECO404ECSLS, BWPECO505ECS

20 Dec 2022

Please read these installation instructions carefully before installing or maintaining this equipment. The product is designed for installation and maintenance in accordance with relevant Australian standards (AS/NZ3000), by an authorised and licensed electrician. The installation instructions were correct at the time of print. To reflect changes in technology and Australian and New Zealand standards; Pierlite reserves the right to amend the instructions without notice. Updated guidelines can be found on relevant brand web site.



### 1. PRODUCT SPECIFICATION:

Product brand	- Pierlite
Type of Protection	- Class I
IP Rating - for interior products, the IP rating nominated is "from below the ceiling" unless specifically nominated.	- IP65
Nominal design Voltage	- 240V

#### Luminaire Specification:

Product Code	Maximum Circuit Wattage (W)	Line Current (A)	In-rush Current (A)	Net Weight of luminaire
BWPECO202ECS	18W	0.085	10.2	1kg
BWPECO404ECSLS	20W/27W/33W/40W	Please refer to details on next page		1.9kg
BWPECO505ECS	52W	0.24	12.7	2.7kg

Important – when installing electronic or HID lighting equipment, the installer must consider the in-rush start current (if any) as documented on the control gear identification label when selecting appropriate circuit controls or protective devices.

Power factor	- 0.90
Nominal Freq. (Hz)	- 50 Hz
Rated Maximum Ambient Temperature	- 0°C - 40°C
Suitable for direct mounting on flammable surfaces	- NO
Dimmable (if relevant refer brand web for approved list)	- NO
IK Rating	- IK08
Installation orientation	- Surface mount (horizontal)
Designed application	- Industrial Interior and Exterior*
Rated average design life	- 54,000 hours (to L70)

**\*For accessible installations, application of the security screws must be employed.**

**For colour select battens, the dip switch located on the gear tray allows the change of colour temperature.**

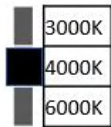

Product Code	3000K	4000K	6000K
BWPECO202ECS	2100lm	2500lm	2100lm
BWPECO404ECSLS	Please refer to details below*		
BWPECO505ECS	5900lm	6200lm	5700lm

**\*BWPECO404ECSLS is colour select and power select weatherproof batten. Factory settings could be altered accordingly by adjusting the DIP switches on the driver.**



DIP SWITCH	SYSTEM WATTAGE (W)
1 2	40
1 2	33
1 2	27
1 2	20

BWPECO404ECSLS System Wattage (W)	Line Current (A)	In-rush Current (A)	Driver settings (mA)	3000K (lm)	4000K (lm)	6000K (lm)
40W	0.185	12.3	300	4700	5200	4600
33W	0.155	12.4	250	4000	4200	3900
27W	0.125	12.5	200	3400	3600	3400
20W	0.095	11.3	150	2500	2700	2500

**2. APPROVALS:** The RCM marking of this product applies to AS/NZS CISPR15 (EMC) "Limits and methods of measurement of radio disturbance characteristics of electrical lighting and similar equipment". This product is designed to conform to AS/NZS60598 "Luminaires, general requirements and tests".



**3. STORAGE:** Prior to installation products are to be stored in cool and dry conditions.

**4. APPLICATION:** The installation application and orientation of the product is designed in accordance with the nominated product IP rating, class designation and these installation instructions. Installation environments and operating conditions beyond these instructions are not recommended.

**5. INSTALLATION / GENERAL:** Installation of the product is to be completed by an authorized and licensed electrician, in accordance with these instructions, relevant Australia standards and local regulations (where applicable). Termination of product wiring, together with the installation of the product must be in a manner and orientation that maintains the integrity of the designated IP rating of the product For electronic control equipment (when supplied) DO NOT MEGGER between A and N.

Warning: The light source contained in this luminaire shall only be replaced by the manufacturer or his service agent or a similar qualified person.

## 6. INSTALLATION / SPECIAL CONDITIONS (relevant only for products approved for such an installation):

- (a) products installed in high wind environments** must have suitable installation / fastening methods applied to ensure the product's mounting points are not damaged through, corrosion, constant vibration and or movement. Exterior products are designed with precise vertical aiming limits, which should not be exceeded. Any vertical floodlight aiming requirements should be specifically validated in writing with the relevant brand before consideration.
- (b) products installed in corrosive or salt laden environments** require special consideration and such; specific product selection, inclusive of suitable fastening methods and extensive ongoing maintenance of products installed in these environments require professional advice. It is essential that all aspects of the product selection, material specification and maintenance are specifically designed for such use and a cleaning program be adopted that maintains the design integrity of the product.
- (c) interior highbay products** must be vertically suspended. The method of suspension (chain etc) must be able to support at least 5 times the total weight of the fitting. Do not install where air movement will cause the fitting to swing about, causing wear and tear of attachment points. Luminaires should be installed where access for maintenance is practical and allows for maintenance to be completed in accordance with the manufacturer's recommendations.
- (d) interior (downlight) products** must be installed to ensure the lamp unit or the driver (if supplied) are not covered with any combustible materials or insulation; minimum spacings nominated for these materials are mandatory. Unless otherwise specified, minimum clearances are in accordance with AS3000 requirements. The product is not designed for installation environments which restrict conventional airflow movements eg: enclosed boxes or concrete profiles. For dimming purposes please see the relevant product brand web site for the dimming compatibility chart. When mounting multiple fixtures to conductive structures, it is recommended that the structure is earthed. The mounting facilities provided for the transformer/driver (if any), need only be utilized if in the application of the product is required by AS3000. IP ratings stated (if any) are from below the ceiling unless stated otherwise and the installation of the product must be in a manner that maintains the integrity of the relevant IP rating.

## 7. MAINTENANCE:

- (a)** The supply must be isolated before opening or accessing the luminaire. Product maintenance is IMPORTANT and is critical to the products designed performance. The product is to be maintained in accordance with the manufacturer's instructions. For the latest product maintenance guides please go to relevant brand web site. GLG is not responsible for any product not maintained in accordance with the recommended procedure or intervals. **(b) lamps (where provided):** The product is designed with the supplied (LEDs) / LAMP/s and it is strongly recommended that any LAMP / (LEDs) changes (if any) be made in accordance with the type, colour and brand supplied. For recommended LAMP / LED maintenance or operating guides (inclusive of recommended product switch cycles and mandatory run-in procedures for HID and Fluorescent lamps when used with dimming circuits), GLG recommends the application of the lamp manufacturer's operating guidelines, which can be found on manufacturer's website. GLG is not responsible for the product performance of alternative lamp/s used. As a member of FluroCycle, we encourage recycling of lamps and components. **(c) battery (where provided):** The battery is designed with a rated average battery design life of 25,000 hours in standby mode. The battery is supported with a standard 3 year warranty; conditional of the product being maintained and operated in accordance with the manufacturer's guidelines and tested in accordance with AS/NZS2293. For guidelines see product installation instructions or visit the relevant brand web site. **(d) for products supplied with glass visors or covers**, do not operate the product with a damaged visor or cover; it is recommended the product be turned off, area surrounding the product vacated and the damaged glass replaced by a professional installer immediately.

## 8. WARRANTY INSTRUCTIONS: For the purpose of warranty claims (if any) the following instructions apply:

**Warranty components** – THE PRODUCT, (identified as the THE PRODUCT only). **Warranty period** – The above components are provided with a warranty of THREE (3) year/s or 15,000 hours of operation (which ever arrives first) against manufacturing defects or failure to perform to specifications for products installed by an authorised installer in accordance with the manufacturer's installation instructions and which have not been subject to incorrect operation or maintenance, unauthorised modification or damage arising from any intervening cause. **Warranty reference** – The warranty reference date commences from the date of purchase. **Warranty point of contact** – GLG Pty Ltd, 96 Gow Street Padstow NSW 2211, phone T 02 9794 9300 contact – GLG After Sales Support.

### **Warranty claim procedure** – For the purpose of making a claim the customer must:

1. Contact the "point of contact" above and upon provision of proof of purchase the customer will receive a goods return advice (GRA) number.
  2. At the customer's expense, collect and return the goods to the "point of contact" with the issued GRA number.
  3. Upon receipt of the goods, GLG will review the claim and if found to be accepted, GLG will return a replacement product to the customer to install at the customer's expense. Alternatively if the claim is rejected, the customer may request the return of the goods at their expense.
- Consumer Contracts** - The benefits to the customer given by the GLG warranty are in addition to other rights and remedies of the customer if the goods are the subject of a Consumer Contract under the Australian Consumer Law. In that event the following statement is required to be brought to the Consumer's attention:- *Our goods come with guarantees that cannot be excluded under the Australian Consumer Law. You are entitled to a replacement or refund for a major failure and for compensation for any other reasonably foreseeable loss or damage. You are also entitled to have the goods repaired or replaced if the goods fail to be of acceptable quality and the failure does not amount to a major failure.* **Limitation of Liability** – if the goods are not purchased by the customer under a Consumer Contract within the Australian Consumer Law then but not otherwise;- (a) the Company is not liable in tort for any loss or damage suffered by the customer or by any third party; and (b) in no circumstances is GLG liable to the customer or to any third party for any loss of profits, loss of anticipated savings, economic loss or interruption of business or for any indirect or consequential loss (Consequential Loss). **Terms of Sale** – these Warranty provisions are in substitution for any inconsistent provisions in the GLG Terms and Conditions of Sale in so far as they apply to the Warranty components.

## INSTALLATION INSTRUCTION

---

### Installation

Step 1: Take the Weatherproof Batten and Accessories out from the packaging.

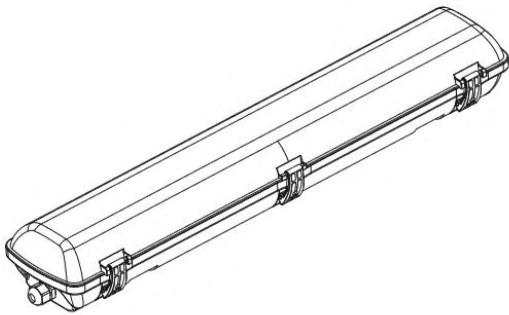

Step 2: Open the Clips

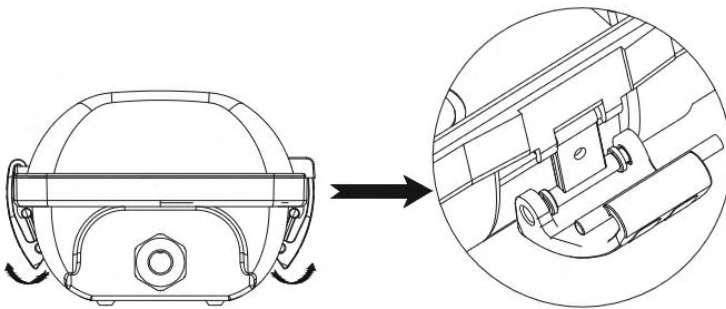

Step 3: Take the gear tray out.

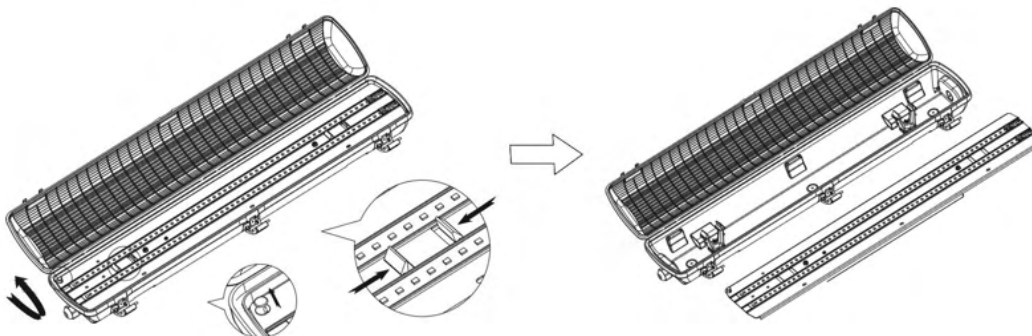

Step 4: Take the cable gland out and connect the AC cable.

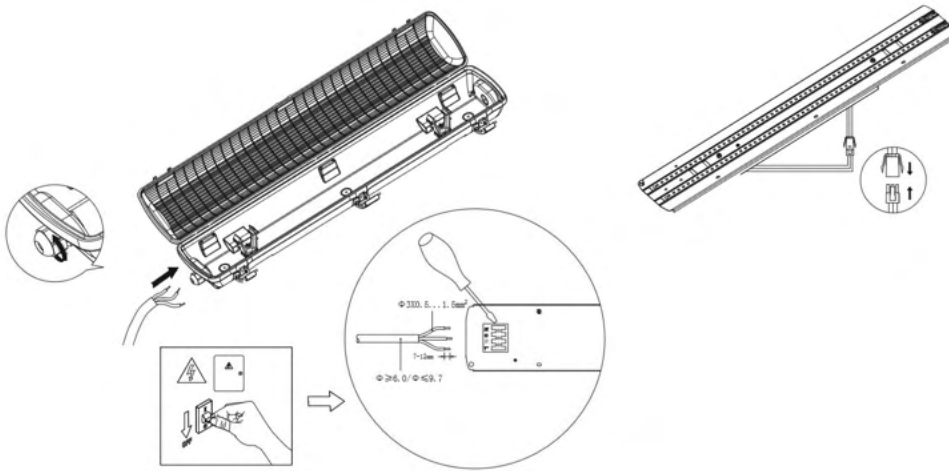

Step 5: Tighten the cable gland

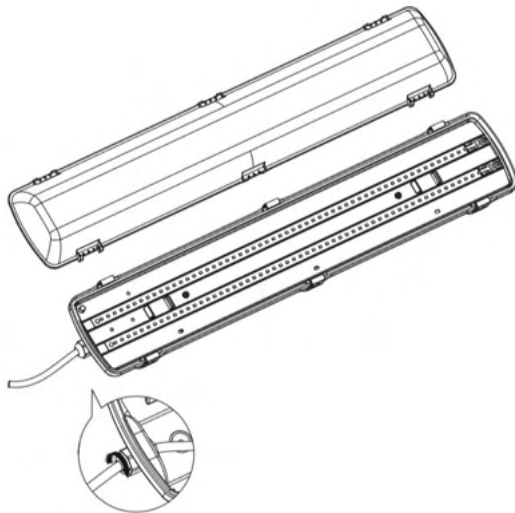

Step 6: Fasten the clips, use 4 screws provided in the accessory bag to lock the clips from 4 corners.

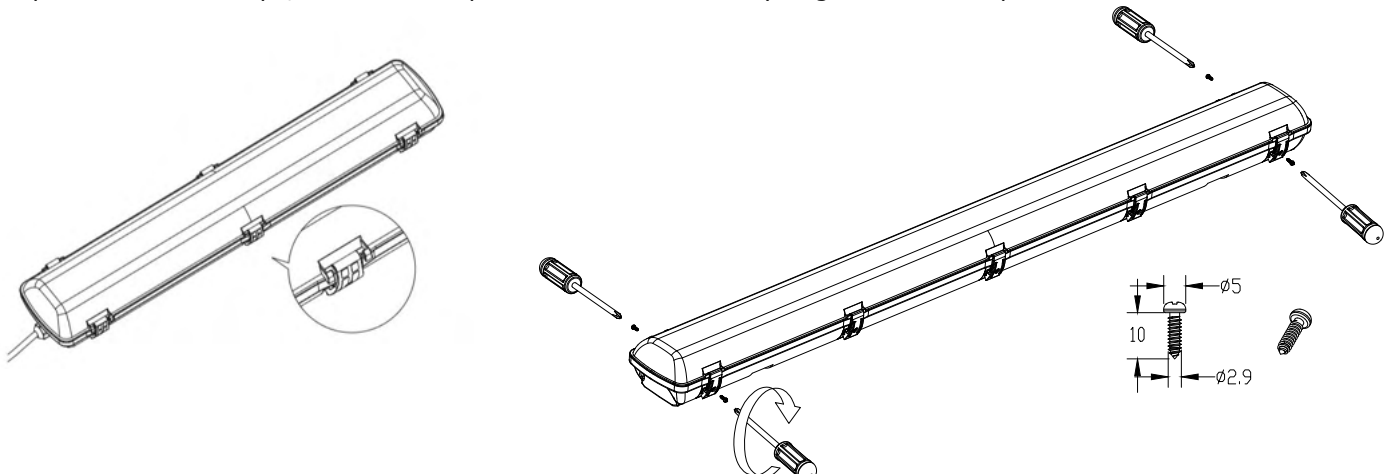

Step 7: Install the batten on the ceiling.

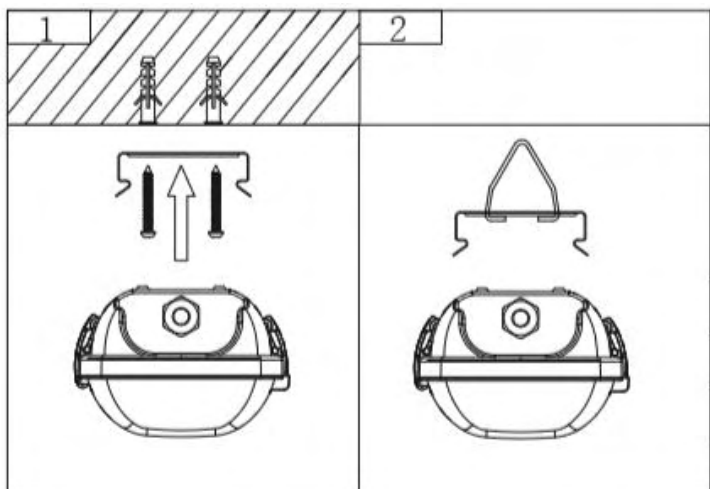

Product Code	L	W	H1	A	H2
BWPECO202ECS	655mm	130mm	92mm	420+/-10mm	99mm
BWPECO404ECSLS	1265mm	130mm	92mm	900+/-10mm	99mm
BWPECO505ECS	1565mm	130mm	92mm	1000+/-10mm	99mm

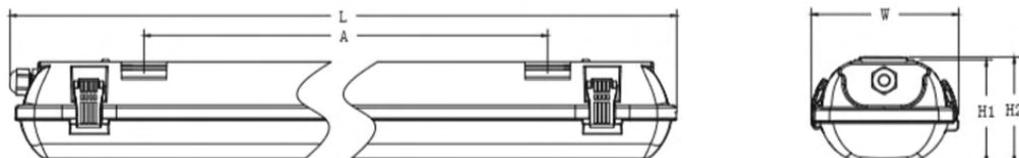



# BWP LED ECO WEATHERPROOF BATTEN

WITH TRI-LEVEL CONTROL HF SENSOR

BWP202D4RCSENS, BWP454D4RCSENS,  
BWP202D3RCSENS, BWP454D4RCSENS,  
BWPECO404ECSS, BWPECO404ECSEMS,  
BWPECO404ECSSLSS2



- 24 hour daylight monitoring dawn/dusk sensor
- Tri-level dimming control based upon occupancy (also known as corridor function)
- 1-10V dimming control method
- One-touch daylight learning via remote control
- Zero crossing detection circuit reduces in-rush current and prolongs relay life
- Loop-in and loop-out terminal for efficient installation

## SENSOR MAIN BODY

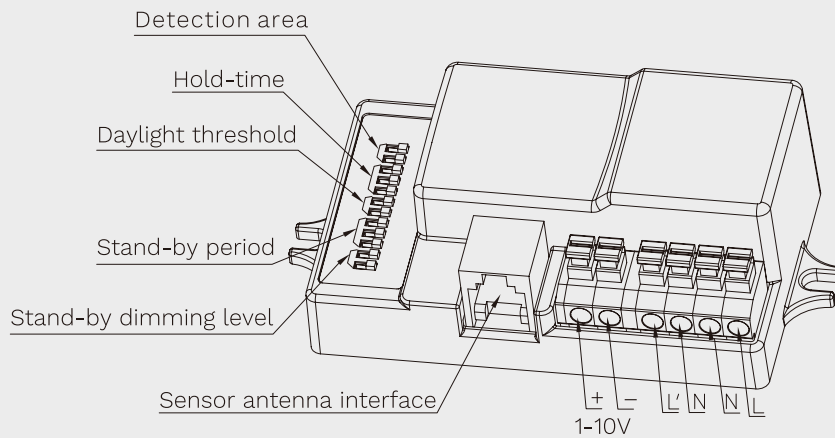

## SENSOR ANTENNA MODULE MODEL SAM5

Super-compact sensor antenna, with optional cable entry (side entry and back entry).

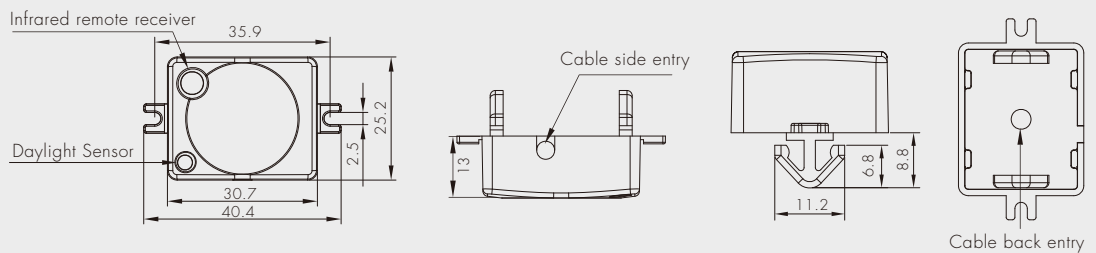

## 1 TRI-LEVEL CONTROL (CORRIDOR FUNCTION)

This function is built inside the motion sensor to achieve tri-level control, for some areas which require a light change notice before switch-off. The sensor offers 3 levels of light: 100% → dimmed light (natural light is insufficient) → off; and 2 periods of selectable waiting time: motion hold-time and stand-by period; Selectable daylight threshold and freedom of detection area.



With sufficient natural light, the light does not switch on when presence is detected.



With insufficient natural light, the sensor switches on the light automatically when presence is detected.

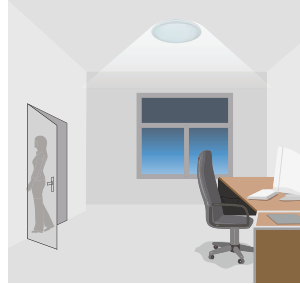

After hold-time, the light dims to stand-by level if the surrounding natural light is below the daylight threshold.



Light switches off automatically after the stand-by period elapses.

## 2 24H DAYLIGHT MONITORING FUNCTION

The software enables the antenna with built-in daylight sensor to provide a “smart photocell” function. This function is activated when stand-by period is set to “+∞”.

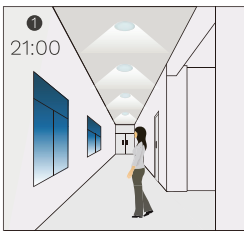

The light switches on at 100% when there is movement detected.

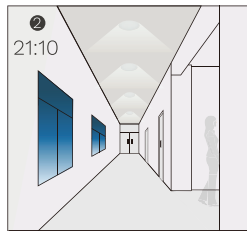

The light dims to stand-by level after the hold-time.

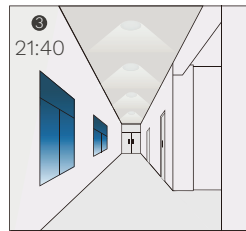

The light remains in dimming level at night.

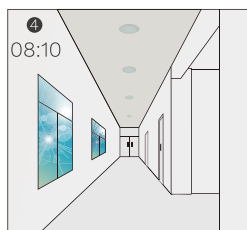
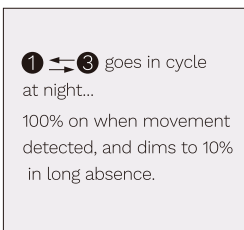

The light turns off completely when natural light lux exceeds daylight.

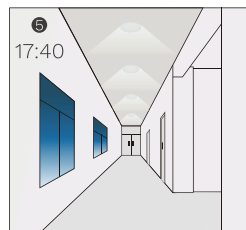

The light automatically turns on at 10% when natural light is insufficient (no light).

### SETTINGS ON THIS DEMONSTRATION

- Hold-time:** 10min
- Daylight threshold:** 50lux
- Stand-by dimming level:** 10%
- Stand-by period:** +∞

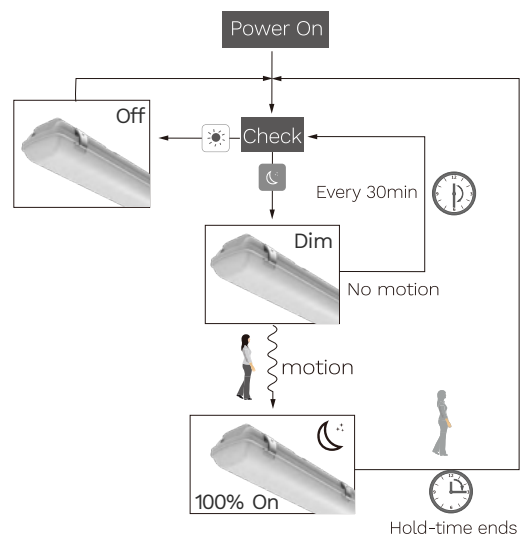



### 3 MANUAL OVERRIDE

This sensor reserves the access of manual override function for end-user to switch on/off, or adjust the brightness by push-switch, which makes the product more user-friendly and offers more options to fit some extra-ordinary demands.

#### **SHORT PUSH (<1S): on/off function;**

**On → off:** the light turns off immediately and cannot be triggered ON by motion until the expiration of pre-set hold-time. After this period, the sensor goes back to normal sensor mode.

**Off → on:** the light turns on and goes to sensor mode, no matter if ambient Lux level exceeds the daylight threshold or not.

#### **LONG PUSH (>1S): adjust the hold-time brightness level between 10% and 100%.**

Note: if end-user do not want this manual override function, just leave the "push" terminal unconnected to any wire.

## DIP SWITCH SETTINGS

### 1 Detection Range

Sensor sensitivity can be adjusted by selecting the combination on the DIP switches to fit precisely for each specific application.

	1	2	
I	●	●	100%
II	●	○	75%
III	○	●	50%
IV	○	○	10%



I – 100%  
II – 75%  
III – 50%  
IV – 10%

### 2 Hold-time

Select the dip switch configuration for the full brightness on-time after presense detection.

*Please note that this function is disabled when the natural daylight exceeds the daylight threshold setting for more than 5 minutes.*

	1	2	3	
I	●	●	●	5s
II	●	●	○	30s
III	●	○	●	1min
IV	●	○	○	5min
V	○	●	●	10min
VI	○	●	○	20min
VII	○	○	○	30min



I – 5s  
II – 30s  
III – 1min  
IV – 5min  
V – 10min  
VI – 20min  
VII – 30min

### 3 Daylight Threshold

Set the level according to the fixture and environment. The light will not turn on if ambient lux level exceeds the daylight threshold preset.

*Please note that the ambient lux level refers to internal light reaching the sensor.*

Disabling the daylight sensor will put the sensor into occupancy detection only mode.

	1	2	
I	●	●	Disable
II	●	○	50Lux
III	○	●	10Lux
IV	○	○	2Lux



I – Disable  
II – 50Lux  
III – 10Lux  
IV – 2Lux

### 4 Stand-by period (corridor function)

This is the time period you would like to keep at the low light output level before it is completely switched off in the long absence of people.

*Note: "0s" means on/off control;*

*"+ ∞" means the stand-by time is infinite and the fixture never switches off.*

	1	2	3	
I	●	●	○	0s
II	●	●	●	10s
III	●	○	●	1min
IV	●	○	○	5min
V	○	●	●	10min
VI	○	●	○	30min
VII	○	○	●	1H
VIII	○	○	○	+∞



I – 0s  
II – 10s  
III – 1min  
IV – 5min  
V – 10min  
VI – 30min  
VII – 1H  
VIII – +∞

### 5 Stand-by dimming level

The setting is used to select the desired dimmed light level used in periods of absence for enhanced comfort and safety.

	1	2	
I	●	●	10%
II	●	○	20%
III	○	●	30%
IV	○	○	50%



I – 10%  
II – 20%  
III – 30%  
IV – 50%

## SETTINGS FOR REMOTE CONTROL (PRC05 TO BE ORDERED SEPERATELY)



### Permanent ON/OFF function

Press the "ON/OFF" button, the light goes to permanent on or permanent off mode, and the sensor is disabled.

\* Press "Auto Mode", "RESET" or "Scene mode" buttons to quit this mode.

**Power Outage Scenario: The sensor has inbuilt functionality of retaining the settings of the remote. However, the ON and OFF function of the remote bypasses the sensor and it's not designed to retain their programmed settings.**

### Auto Mode

#### Sensor mode

Press "Auto Mode" button, the sensor starts to function and all settings remain the same as the latest status before the light is switched on/off.



### Reset function

Press "RESET" button, all settings go back to default settings.



### Dim +/-

Long press "Dim +" or "Dim -" to adjust the light brightness during hold-time. "+" means dimming up, "-" means dimming down.



### Test mode

This button is for testing purpose only. The sensor goes to test mode (hold-time is 2s) after commissioning, meanwhile the stand-by period and daylight sensor are disabled.

\* This mode can be ended by pressing "reset", or any button of "scene mode" and "hold-time". The sensor settings are changed accordingly.



### Power output

By pressing these two buttons, the output shifts between 80% (at initial 10,000 hours) and 100%, for energy saving purpose.



### Ambient daylight threshold

Press this button, the latest surrounding lux value overwrites the previous lux value learned, and it is set as the daylight threshold. This feature enables the fixture to function well in any real application circumstances.

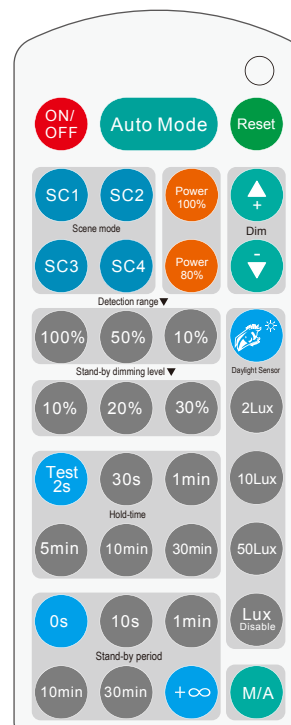

*Note: the buzzer beeps one time when RC receives signal successfully.*

## SETTINGS (REMOTE CONTROL FOR SAM5 TO BE ORDERED SEPERATELY)

### Lux disable

Press this button, the built-in daylight sensor stops working, and all motion detected could turn on the lighting fixture, no matter how bright the natural light is.

### Manual override / Semi-auto mode (absence detection)

By pressing this button, the sensor goes to manual override or Semi-auto mode (absence detection) function.

\* The buzzer beeps twice if it's manual override function, and beeps once if it shifts to Semi-auto mode (absence detection).

*Please note that this button is valid for HC404VRC-KD ONLY.*

### Scene mode

There are 4 scene modes fixed program built in the remote control to choose for different applications:

Scene options	Detection range	Hold-time	Stand-by period	Stand-by dimming level	Daylight sensor
SC1	100%	1min	10min	10%	2Lux
SC2	100%	5min	10min	10%	2Lux
SC3	100%	10min	30min	10%	10Lux
SC4	100%	10min	+∞	10%	50Lux

\* End-user can adjust the settings by pressing buttons of detection range/hold-time/stand-by period/stand-by dimming level/daylight sensor. The last setting stays in validity.

### Detection range

Press the buttons of "detection range" to set detection range at 10% / 50% / 100%.

### Hold-time

Press the buttons of "hold-time" to set hold-time at 30s / 1min / 5min / 10min / 30min.

### Daylight sensor

Press the buttons of "daylight sensor" to set daylight threshold at 2Lux / 10Lux / 50Lux.

### Stand-by period (corridor function)

Press the buttons of "stand-by period" to set stand-by period at 0s / 10s / 1min / 10min / 30min / +∞.

\* "0s" means on/off control; "+∞" means bi-level dimming control, the fixture never switches off when daylight sensor is disabled.

### Stand-by dimming level

Press the buttons of "stand-by dimming level" to set the stand-by dimming level at 10% / 20% / 30%.

## Detection Pattern (Ceiling mounted)

Model SAM5

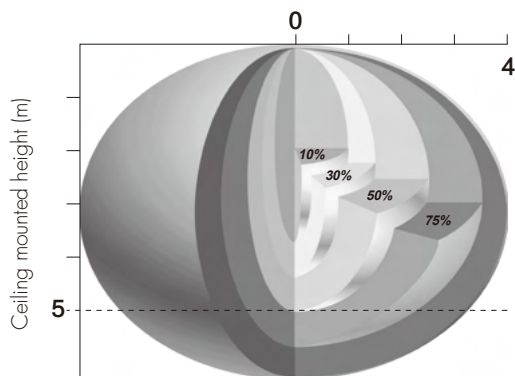

Model SAM6

