

## INSTALLATION / WARRANTY INSTRUCTIONS

Issue date: 01 December 2020

**PRODUCT BRAND** Pierlite

**PRODUCT NAME / CODES** UNILUX / SEPLED124LSPA

For authorized codes configurations please refer to the installation instructions and driver rating label for electrical ratings.

**PLEASE READ THESE INSTALLATION INSTRUCTIONS CAREFULLY BEFORE INSTALLING OR MAINTAINING THIS EQUIPMENT. THE PRODUCT IS DESIGNED FOR INSTALLATION AND MAINTENANCE IN ACCORDANCE WITH RELEVANT AUSTRALIAN STANDARDS (AS3000) AND LOCAL REGULATIONS (WHERE APPLICABLE), BY AN AUTHORISED AND LICENCED ELECTRICIAN.** THE INSTALLATION INSTRUCTIONS WERE CORRECT AT THE TIME OF PRINT. TO REFLECT CHANGES IN TECHNOLOGY AND AUSTRALIAN STANDARDS; PIERLITE RESERVES THE RIGHT TO AMEND THE INSTRUCTIONS WITHOUT NOTICE. UPDATED GUIDELINES CAN BE FOUND ON THE RELEVANT BRAND WEB SITE.

**IMPORTANT** - THE PRODUCT MUST BE MAINTAINED AND OPERATED IN ACCORDANCE WITH THE MANUFACTURER'S INSTRUCTIONS, FAILURE TO DO SO MAY DAMAGE THE PRODUCT AND SERVICES. IT IS STRONGLY RECOMMENDED THAT THIS IMPORTANT NOTE BE COMMUNICATED TO THE OWNER AND OR OPERATOR OF THE INSTALLATION AT THE TIME OF SITE COMMISSIONING. GOOD PRACTICE DOES NOT RECOMMEND THE 24/7 USE OF PRODUCTS WITHOUT THE APPLICATION OF SUITABLE SWITCH CYCLE INTERVALS. FURTHERMORE, WITH THE OMISSION OF NOMINATED SURVIVAL CURVES AND OR RECOMMENDED OPERATING HOURS, PRODUCT DESIGN EXPECTATIONS PROVIDE FOR A CONTINUAL DAILY USAGE OF 6 HOURS FOR RESIDENTIAL APPLICATIONS AND A CONTINUAL DAILY USAGE OF 12 HOURS FOR COMMERCIAL AND INDUSTRIAL APPLICATIONS. ALL PRODUCTS MUST BE THOROUGHLY CLEANED ON A REGULAR BASIS AT INTERVALS THAT REFLECT IN THE INSTALLATION ENVIRONMENT, ENSURING THE OPTICAL PERFORMANCE, TOGETHER WITH THE ELECTRICAL, MECHANICAL AND STRUCTURAL INTEGRITY AS DESIGNED, IS MAINTAINED THROUGHOUT THE SERVICE LIFE OF THE PRODUCT.



### General Guideline for Assembling the Product:

Thank you for choosing Pierlite UNILUX LED linear surface mount quality product.

- The UNILUX SEPLED124LSPA will come in two (2) separate parts:
  - o A Body cluster kit that contains LED electronics (Item No. SEPLED124LSPA-K). Together there will be a pack of tensile steel spring clips (4 pcs) and a set of rubber adhesive Cover Pads (4 pcs).
  - o A Diffuser Cover that is made out high impact acrylic. (Item No. DIF-SEPLED124)
- Unpack the body cluster and diffuser cover from its packaging.
- Follow steps 1 to 6.

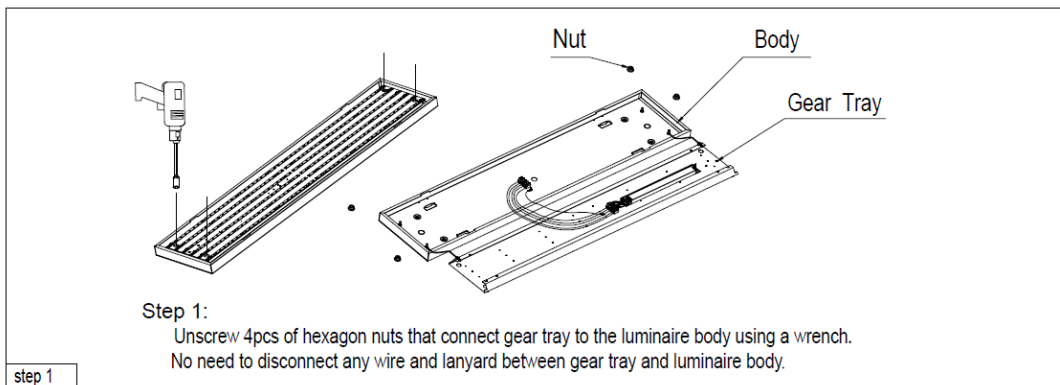

Spring Clip

Body

Back View

COVER PADS

COVER PADS

Step 2:

2.1 Insert the spring clips into 2 pin holes by pinching the foot of the spring clip and turn the spring clip 90 degrees. Complete for all the four (4) locations.

2.2 Peel of adhesive and attach COVER PADS (4pcs) into the open are as indicated below to stop dust and dirt getting into the product.

2.3 Peel of adhesive and attach COVER PADS (4pcs) into the open are as indicated below to stop dust and dirt getting into the product.

step 2

Mounting Hole Spacing Diagram

150

1000

Ceiling

Body

Gear Tray

Step 3:

3.1 Determine the position where you want to install.

3.2 Drill 4 holes in the ceiling as per mounting hole spacing diagram.

3.3 Pull the AC power supply cable through the cable entry hole of the body

3.4 Fix luminaire body onto the ceiling firmly with 4pcs of expansion screws.

step 3

Body

Gear Tray

8

30

AC-A(Brown)

GND-(Yellow/Green)

AC-N(Blue)

DA(Red)

DA(Black)

Step 4:

Connect the AC power supply cable to the terminal block of luminaire body as shown in the wiring diagram. Then tighten the screws on the terminal block with a screwdriver to ensure a firm connection.

step 4

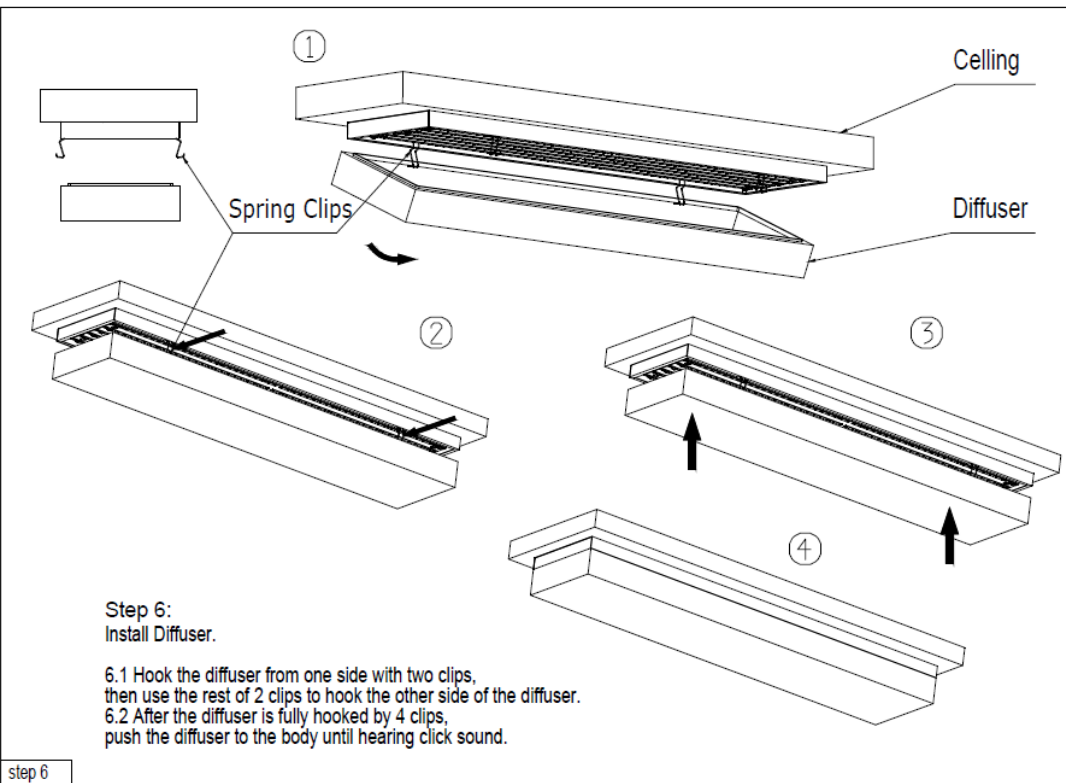
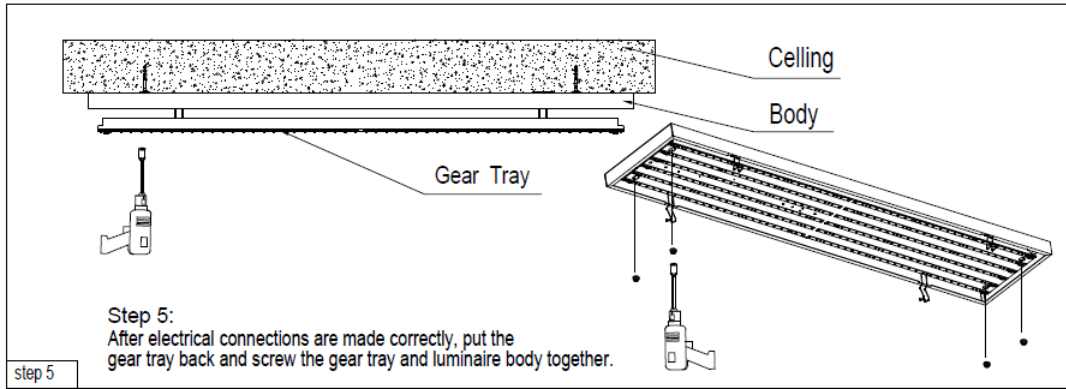

**1. PRODUCT SPECIFICATION:**

Product brand	- Pierlite
Type of Protection	- Class I
IP Rating- for interior products, the IP rating is "from below the ceiling" unless specifically nominated.	- IP20
Nominal design Voltage	- 240V
Circuit wattage (System Power)	- refer to table
Line current	- refer to table
Important – when installing electronic or HID lighting equipment, the installer must consider the in-rush start current (if any) as documented on the control gear identification label when selecting appropriate circuit controls or protective devices.	
Power factor	- >0.85
Nominal Freq. (Hz)	- 50 Hz
Rated Minimum / Maximum Ambient Temperature	- 0°C / 40°C
Suitable for direct mounting on flammable surfaces	- NO
Dimmable (if relevant refer brand web for approved list)	- DALI
Installation orientation	- Horizontal face down
Designed application	- Interior commercial
Rated average design life	- 72,000hrs (L70)

Product Code	Description	Body Cluster Code	Diffuser Code	System Power (W)	Driver Settings (mA)	Lumen Output (Lm)	Line Current (A)	In-Rush Current
SEPLED124LSPA	UNILUX LED SEP 1200 54W LUM SEL 4K DALI	SEPLED124LSPA-K	DIF- SEPLED124	54	1400	7400	0.238	13.0A/39.2uS
				35	900	4950	0.162	13.0A/39.2uS
				30 (default)	800	4490	0.153	13.2A/39.2uS
				23	600	3400	0.118	13.0A/40.0uS

## LINE DRAWINGS

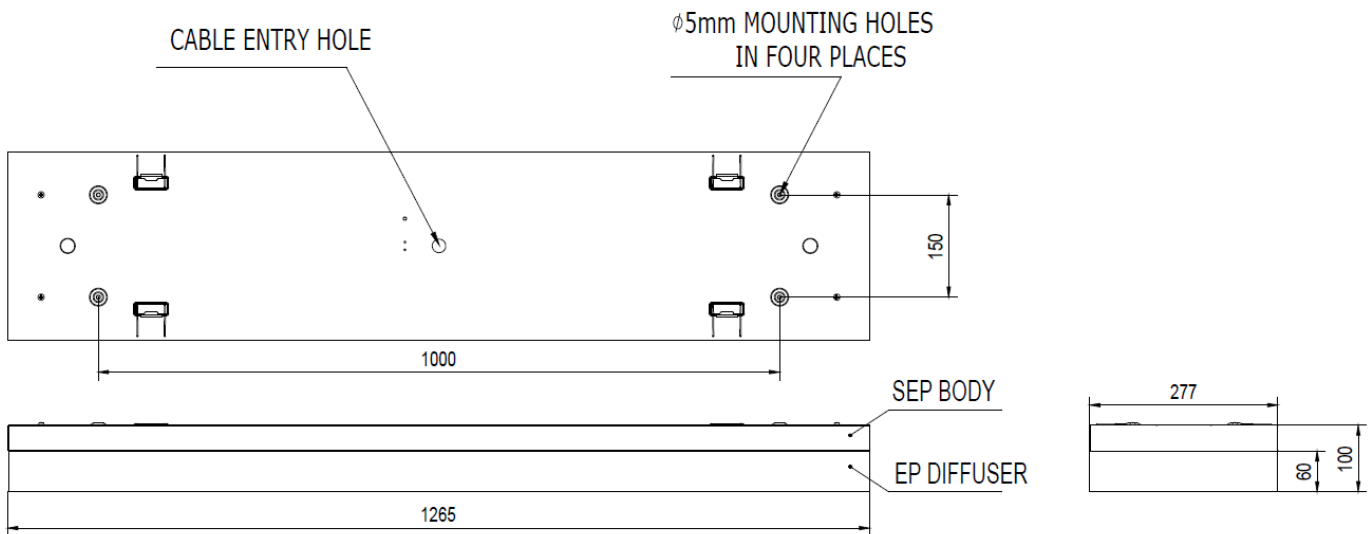

**2. APPROVALS:** The RCM marking of this product applies to AS/NZS CISPR15 (EMC) "Limits and methods of measurement of radio disturbance characteristics of electrical lighting and similar equipment". This product is designed to conform to AS/NZS60598 "Luminaires, general requirements and tests".



**3. STORAGE:** Prior to installation products are to be stored in cool and dry conditions.

**4. APPLICATION:** The installation application and orientation of the product is designed in accordance with the nominated product IP rating, class designation and these installation instructions. Installation environments and operating conditions beyond these instructions are not recommended.

**5. INSTALLATION / GENERAL:** Installation of the product is to be completed by an authorized and licensed electrician, in accordance with these instructions, relevant Australia standards and local regulations (where applicable). Termination of product wiring, together with the installation of the product must be in a manner and orientation that maintains the integrity of the designated IP rating of the product For electronic control equipment (when supplied) DO NOT MEGGER between A and N.

**6. INSTALLATION / SPECIAL CONDITIONS** (relevant only for products approved for such an installation):

**(a) products installed in high wind environments** must have suitable installation / fastening methods applied to ensure the product's mounting points are not damaged through, corrosion, constant vibration and or movement. Exterior products are designed with precise vertical aiming limits, which should not be exceeded. Any vertical floodlight aiming requirements should be specifically validated in writing with the relevant brand before consideration.

**(b) products installed in corrosive or salt laden environments** require special consideration and such; specific

product selection, inclusive of suitable fastening methods and extensive ongoing maintenance of products installed in these environments require professional advice. It is essential that all aspects of the product selection, material specification and maintenance are specifically designed for such use and a cleaning program be adopted that maintains the design integrity of the product.

**(c) interior high bay products** must be vertically suspended. The method of suspension (chain etc) must be able to support at least 5 times the total weight of the fitting. Do not install where air movement will cause the fitting to swing about, causing wear and tear of attachment points. Luminaires should be installed where access for maintenance is practical and allows for maintenance to be completed in accordance with the manufacturer's recommendations.

**(d) interior (downlight) products** must be installed to ensure the lamp unit or the driver (if supplied) are not covered with any combustible materials or insulation; minimum spacings nominated for these materials are mandatory. Unless otherwise specified, minimum clearances are in accordance with AS3000 requirements. The product is not designed for installation environments which restrict conventional airflow movements eg: enclosed boxes or concrete profiles. For dimming purposes please see the relevant product brand web site for the dimming compatibility chart. When mounting multiple fixtures to conductive structures, it is recommended that the structure is earthed. The mounting facilities provided for the transformer/driver (if any), need only be utilized if in the application of the product is required by AS3000. IP ratings stated (if any) are from below the ceiling unless stated otherwise and the installation of the product must be in a manner that maintains the integrity of the relevant IP rating.

**7. MAINTENANCE:** **(a)** The supply must be isolated before opening or accessing the luminaire. Product maintenance is IMPORTANT and is critical to the products designed performance. The product is to be maintained in accordance with the manufacturer's instructions. For the latest product maintenance guides please go to relevant brand web site. Pierlite is not responsible for any product not maintained in accordance with the recommended procedure or intervals. **(b) lamps (where provided):** The product is designed with the supplied (LEDs) / LAMP/s and it is strongly recommended that any LAMP / (LEDs) changes (if any) be made in accordance with the type, colour and brand supplied. For recommended LAMP / LED maintenance or operating guides (inclusive of recommended product switch cycles and mandatory run-in procedures for HID and Fluorescent lamps when used with dimming circuits), Pierlite recommends the application of the lamp manufacturer's operating guidelines, which can be found on manufacturer's website. Pierlite is not responsible for the product performance of alternative lamp/s used. As a member of FluroCycle, we encourage recycling of lamps and components. **(c) battery (where provided):** The battery is designed with a rated average battery design life of 25,000 hours in standby mode. The battery is supported with a standard 12 months warranty; conditional of the product being maintained and operated in accordance with the manufacturer's guidelines and tested in accordance with AS/NZS2293. For guidelines see product installation instructions or visit the relevant brand web site. **(d) for products supplied with glass visors or covers,** do not operate the product with a damaged visor or cover; it is recommended the product be turned off, area surrounding the product vacated and the damaged glass replaced by a professional installer immediately.

**8. WARRANTY INSTRUCTIONS:** For the purpose of warranty claims (if any) the following instructions apply: **Warranty components** – THE PRODUCT, (identified as the THE PRODUCT only). **Warranty period** - The above components are provided with a warranty of FIVE (5) year/s or 25,000 hrs. of operation (which ever arrives first) against manufacturing defects or failure to perform to specifications for products installed by an authorised installer in accordance with the manufacturer's installation instructions and which have not been subject to incorrect operation or maintenance, unauthorised modification or damage arising from any intervening cause. **Warranty reference** - The warranty reference date commences from the date of purchase. **Warranty point of contact** – Pierlite Pty Ltd, 96 Gow Street Padstow NSW 2211, phone T: 02 9794 9300. Contact Pierlite After Sales Support.

**Warranty claim procedure** – For the purpose of making a claim the customer must:

1. Contact the "point of contact" above and upon provision of proof of purchase the customer will receive a goods return advice (GRA) number. 2. At the customer's expense, collect and return the goods to the "point of contact" with the issued GRA number. 3. Upon receipt of the goods, Pierlite will review the claim and if found to be accepted, Pierlite will return a replacement product to the customer to install at the customer's expense. Alternatively, if the claim is rejected, the customer may request the return of the goods at their expense. **Consumer Contracts** - The benefits to the customer given by the Pierlite warranty are in addition to other rights and remedies of the customer if the goods are the subject of a Consumer Contract under the Australian Consumer Law. In that event the following statement is required to be brought to the Consumer's attention: *Our goods come with guarantees that cannot be excluded under the Australian Consumer Law. You are entitled to a replacement or refund for a major failure and for compensation for any other reasonably foreseeable loss or damage. You are also entitled to have the goods repaired or replaced if the goods fail to be of acceptable quality and the failure does not amount to a major failure.* **Limitation of Liability** – if the goods are not purchased by the customer under a Consumer Contract within the Australian Consumer Law then but not otherwise;- (a) the Company is not liable in tort for any loss or damage suffered by the customer or by any third party; and (b) in no circumstances is Pierlite liable to the customer or to any third party for any loss of profits, loss of anticipated savings, economic loss or interruption of business or for any indirect or consequential loss (Consequential Loss). **Terms of Sale** – these Warranty provisions are in substitution for any inconsistent provisions in the Pierlite Terms and Conditions of Sale in so far as they apply to the Warranty components.