

INSTALLATION / WARRANTY INSTRUCTIONS

issue date: 7/3/2021

PRODUCT BRAND - PIERLITE
PRODUCT NAME / CODES - Aether UVC Troffer/ AETUVC12349D

PLEASE READ THESE INSTALLATION INSTRUCTIONS CAREFULLY BEFORE INSTALLING OR MAINTAINING THIS EQUIPMENT. THE PRODUCT IS DESIGNED FOR INSTALLATION AND MAINTENANCE IN ACCORDANCE WITH RELEVANT AUSTRALIAN STANDARDS (AS3000) AND LOCAL REGULATIONS (WHERE APPLICABLE), BY AN AUTHORISED AND LICENCED ELECTRICIAN. THE INSTALLATION INSTRUCTIONS WERE CORRECT AT THE TIME OF PRINT. TO REFLECT CHANGES IN TECHNOLOGY AND AUSTRALIAN STANDARDS; PIERLITE RESERVES THE RIGHT TO AMEND THE INSTRUCTIONS WITHOUT NOTICE. UPDATED GUIDELINES CAN BE FOUND ON THE RELEVANT BRAND WEB SITE.

IMPORTANT - THE PRODUCT MUST BE MAINTAINED AND OPERATED IN ACCORDANCE WITH THE MANUFACTURER'S INSTRUCTIONS, FAILURE TO DO SO MAY DAMAGE THE PRODUCT AND SERVICES. IT IS STRONGLY RECOMMENDED THAT THIS IMPORTANT NOTE BE COMMUNICATED TO THE OWNER AND OR OPERATOR OF THE INSTALLATION AT THE TIME OF SITE COMMISSIONING. GOOD PRACTICE DOES NOT RECOMMEND THE 24/7 USE OF PRODUCTS WITHOUT THE APPLICATION OF SUITABLE SWITCH CYCLE INTERVALS. FURTHERMORE, WITH THE OMISSION OF NOMINATED SURVIVAL CURVES AND OR RECOMMENDED OPERATING HOURS, PRODUCT DESIGN EXPECTATIONS PROVIDE FOR A CONTINUAL DAILY USAGE OF 6 HOURS FOR RESIDENTIAL APPLICATIONS AND A CONTINUAL DAILY USAGE OF 12 HOURS FOR COMMERCIAL AND INDUSTRIAL APPLICATIONS. ALL PRODUCTS MUST BE THOROUGHLY CLEANED ON A REGULAR BASIS AT INTERVALS THAT REFLECT IN THE INSTALLATION ENVIRONMENT, ENSURING THE OPTICAL PERFORMANCE, TOGETHER WITH THE ELECTRICAL, MECHANICAL AND STRUCTURAL INTEGRITY AS DESIGNED, IS MAINTAINED THROUGHOUT THE SERVICE LIFE OF THE PRODUCT.

1. PRODUCT SPECIFICATION:

Product brand - Pierlite
Type of Protection - Class II
IP Rating - for interior products, the IP rating nominated is "from below the ceiling" unless specifically nominated. - IP20
Nominal design Voltage - 240V
Luminaire Specification:

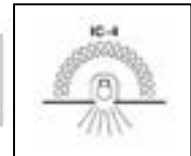

Building insulation may abut the sides of the luminaire.

Product Code	Wattage (W)	Driver Settings (mA)	Line Current (A)	Lumens Output (lm)	Inrush Current	Remark
AETUVC12349D	36W	900 mA	0.15A	3600 lm	13.7A/260us	
	32W	800 mA	0.13A	3200 lm	13.7A/250us	
	28W	700 mA	0.11A	2800 lm	12.3A/250us	Default settings
	24W	600 mA	0.10A	2400 lm	12.7A/260us	
	22W	550 mA	0.09A	2200 lm	13.3A/280us	

DC Motor Table (Power consumption of Luminaire not included)

Product	Maximum Wattage	Line Current	RPM	Maximum Current
DC Motor	21.5W	1A	1010	<5A

Luminaire + DC Motor + UVC LED Module

Product	Maximum Wattage	Line Current	Inrush Current
AETUVC12349D (Luminaire + DC Motor + UVC Module)	60W	0.29A	13.1A /344 us

Important – when installing electronic or HID lighting equipment, the installer must consider the in-rush start current (if any) as documented on the control gear identification label when selecting appropriate circuit controls or protective devices.

Power factor - >0.9
Nominal Freq. (Hz) - 50 Hz
Rated Maximum Ambient Temperature - 40°C
Suitable for direct mounting on flammable surfaces - YES
Dimmable (if relevant refer brand web for approved list) - Yes (DALI Dimming)
Installation orientation - Recessed Mount
Designed application - Commercial Interior
Rated average design life - 54,000 hours (to L70)
Weight -7kg

***For accessible installations, application of the security screws must be employed.**

2. APPROVALS: The RCM marking of this product applies to AS/NZS CISPR15 (EMC) "Limits and methods of measurement of radio disturbance characteristics of electrical lighting and similar equipment". This product is designed to conform to AS/NZS60598 "Luminaires, general requirements and tests".



3. STORAGE: Prior to installation products are to be stored in cool and dry conditions.

4. APPLICATION: The installation application and orientation of the product is designed in accordance with the nominated product IP rating, class designation and these installation instructions. Installation environments and operating conditions beyond these instructions are not recommended.

5. INSTALLATION / GENERAL: Installation of the product is to be completed by an authorized and licensed electrician, in accordance with these instructions, relevant Australia standards and local regulations (where applicable). Termination of product wiring, together with the installation of the product must be in a manner and orientation that maintains the integrity of the designated IP rating of the product For electronic control equipment (when supplied) DO NOT MEGGER between A and N.

6. INSTALLATION / SPECIAL CONDITIONS (relevant only for products approved for such an installation):

(a) products installed in high wind environments must have suitable installation / fastening methods applied to ensure the product's mounting points are not damaged through, corrosion, constant vibration and or movement. Exterior products are designed with precise vertical aiming limits, which should not be exceeded. Any vertical floodlight aiming requirements should be specifically validated in writing with the relevant brand before consideration.

(b) products installed in corrosive or salt laden environments require special consideration and such; specific product selection, inclusive of suitable fastening methods and extensive ongoing maintenance of products installed in these environments require professional advice. It is essential that all aspects of the product selection, material specification and maintenance are specifically designed for such use and a cleaning program be adopted that maintains the design integrity of the product.

(c) interior highbay products must be vertically suspended. The method of suspension (chain etc) must be able to support at least 5 times the total weight of the fitting. Do not install where air movement will cause the fitting to swing about, causing wear and tear of attachment points. Luminaires should be installed where access for maintenance is practical and allows for maintenance to be completed in accordance with the manufacturer's recommendations.

(d) interior (downlight) products must be installed to ensure the lamp unit or the driver (if supplied) are not covered with any combustible materials or insulation; minimum spacings nominated for these materials are mandatory. Unless otherwise specified, minimum clearances are in accordance with AS3000 requirements. The product is not designed for installation environments which restrict conventional airflow movements eg: enclosed boxes or concrete profiles. For dimming purposes please see the relevant product brand web site for the dimming compatibility chart. When mounting multiple fixtures to conductive structures, it is recommended that the structure is earthed. The mounting facilities provided for the transformer/driver (if any), need only be utilized if in the application of the product is required by AS3000. IP ratings stated (if any) are from below the ceiling unless stated otherwise and the installation of the product must be in a manner that maintains the integrity of the relevant IP rating.

7. MAINTENANCE:

(a) The supply must be isolated before opening or accessing the luminaire. Product maintenance is IMPORTANT and is critical to the products designed performance. The product is to be maintained in accordance with the manufacturer's instructions. For the latest product maintenance guides please go to relevant brand web site. Pierlite is not responsible for any product not maintained in accordance with the recommended procedure or intervals. **(b) lamps (where provided):** The product is designed with the supplied (LEDs) / LAMP/s and it is strongly recommended that any LAMP / (LEDs) changes (if any) be made in accordance with the type, colour and brand supplied. For recommended LAMP / LED maintenance or operating guides (inclusive of recommended product switch cycles and mandatory run-in procedures for HID and Fluorescent lamps when used with dimming circuits), PIERLITE recommends the application of the lamp manufacturer's operating guidelines, which can be found on manufacturer's website. PIERLITE is not responsible for the product performance of alternative lamp/s used. As a member of FluroCycle, we encourage recycling of lamps and components. **(c) battery (where provided):** The battery is designed with a rated average battery design life of 25,000 hours in standby mode. The battery is supported with a standard 3 year warranty; conditional of the product being maintained and operated in accordance with the manufacturer's guidelines and tested in accordance with AS/NZS2293. For guidelines see product installation instructions or visit the relevant brand web site. **(d) for products supplied with glass visors or covers**, do not operate the product with a damaged visor or cover; it is recommended the product be turned off, area surrounding the product vacated and the damaged glass replaced by a professional installer immediately.

8. WARRANTY INSTRUCTIONS: For the purpose of warranty claims (if any) the following instructions apply:

Warranty components – THE PRODUCT, (identified as the THE PRODUCT only). **Warranty period** -

- 5-year warranty for UV device housing, mechanical, white light-emitting components, ballast, and driver or Maximum 50,000 hrs
- 3-year warranty on UV device fans and other electrical components or Maximum 30,000 hrs
- 2-year warranty on UV-C led or Maximum 15,000 hrs
- 6 months warranty on HEPA filter

The above components are provided with a warranty against manufacturing defects or failure to perform to specifications for products installed by an authorised installer in accordance with the manufacturer's installation instructions and which have not been subject to incorrect operation or maintenance, unauthorised modification or damage arising from any intervening cause.

Warranty reference - The warranty reference date commences from the date of purchase. **Warranty point of contact** – PIERLITE Pty Ltd, 96 Gow Street Padstow NSW 2211, phone T 02 9794 9300 contact – PIERLITE After Sales Support.

Warranty claim procedure – For the purpose of making a claim the customer must:

1. Contact the “point of contact” above and upon provision of proof of purchase the customer will receive a goods return advice (GRA) number.
2. At the customer’s expense, collect and return the goods to the “point of contact” with the issued GRA number.
3. Upon receipt of the goods, PIERLITE will review the claim and if found to be accepted, PIERLITE will return a replacement product to the customer to install at the customer’s expense. Alternatively if the claim is rejected, the customer may request the return of the goods at their expense.

Consumer Contracts - The benefits to the customer given by the PIERLITE warranty are in addition to other rights and remedies of the customer if the goods are the subject of a Consumer Contract under the Australian Consumer Law. In that event the following statement is required to be brought to the Consumer’s attention: - *Our goods come with guarantees that cannot be excluded under the Australian Consumer Law. You are entitled to a replacement or refund for a major failure and for compensation for any other reasonably foreseeable loss or damage. You are also entitled to have the goods repaired or replaced if the goods fail to be of acceptable quality and the failure does not amount to a major failure.*

Limitation of Liability – if the goods are not purchased by the customer under a Consumer Contract within the Australian Consumer Law then but not otherwise; - (a) the Company is not liable in tort for any loss or damage suffered by the customer or by any third party; and (b) in no circumstances is PIERLITE liable to the customer or to any third party for any loss of profits, loss of anticipated savings, economic loss or interruption of business or for any indirect or consequential loss (Consequential Loss).

Terms of Sale – these Warranty provisions are in substitution for any inconsistent provisions in the PIERLITE Terms and Conditions of Sale in so far as they apply to the Warranty components.

Installation Instructions

Line Drawing

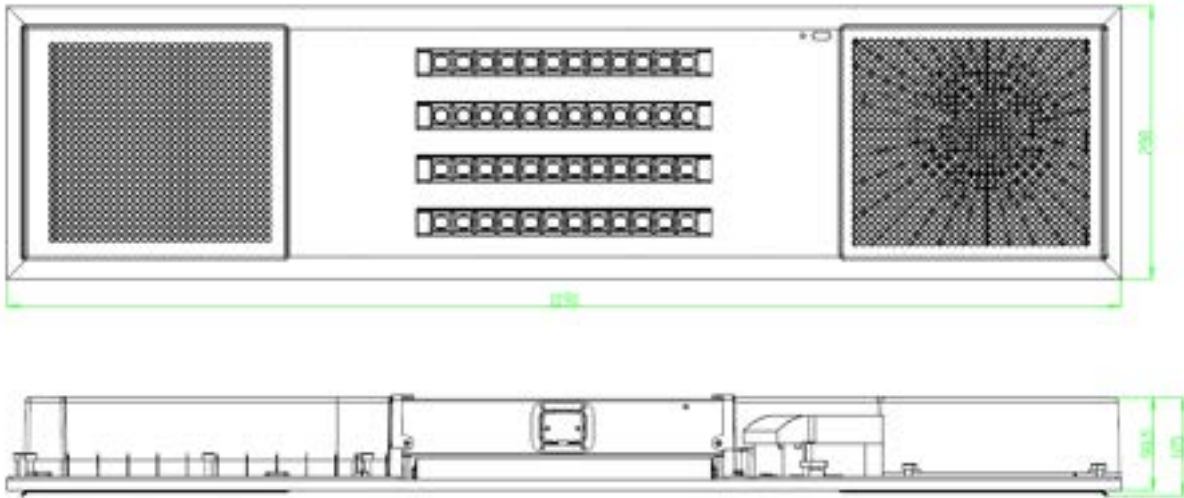

Installation Steps (Recessed mount):

- Turn off the power source before installing.
- Carefully unpack the unit and inspect it for defects before installation.
- Remove the ceiling tile from the area where the Aether Troffer will be installed. (A1)

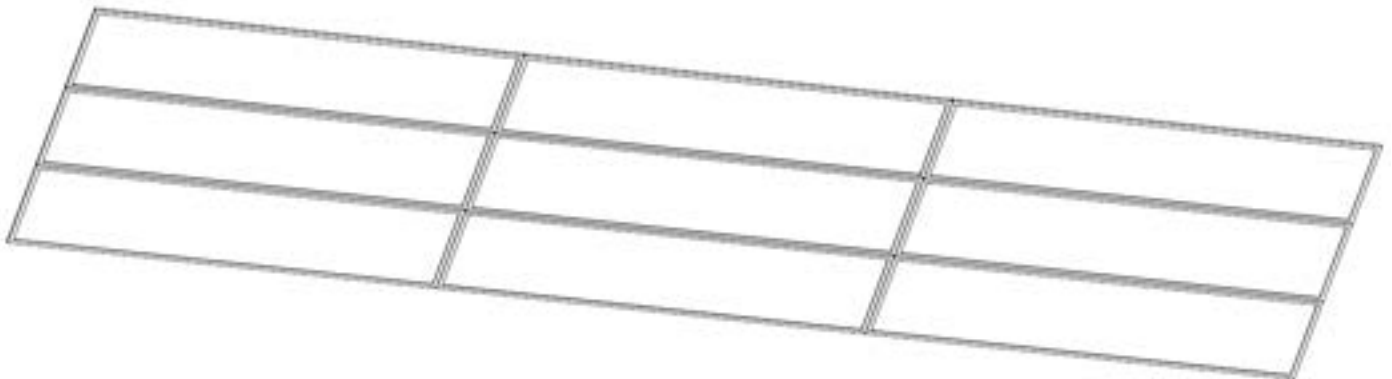

(A1)

- Check the position of the safety wire (A2) before installation, and if there is no suitable bracket structure, install expansion screws first.

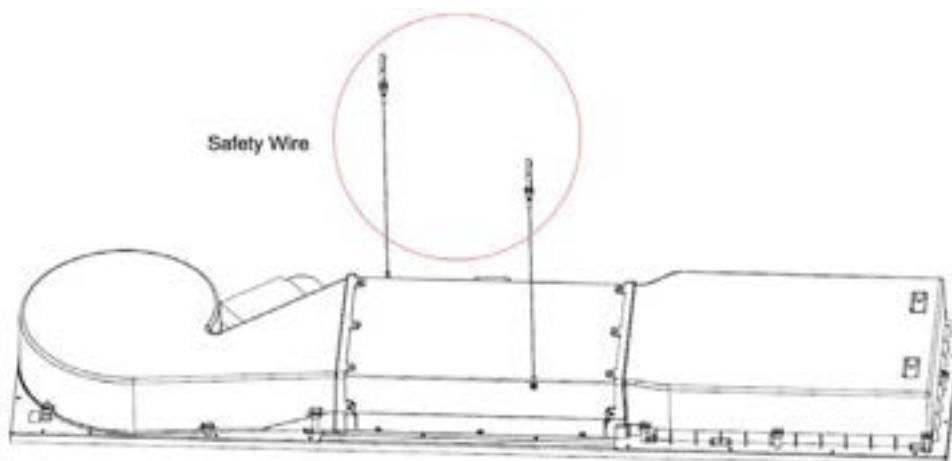

(A2)

- Install the troffer in the appropriate ceiling cavity. (A3/A4)

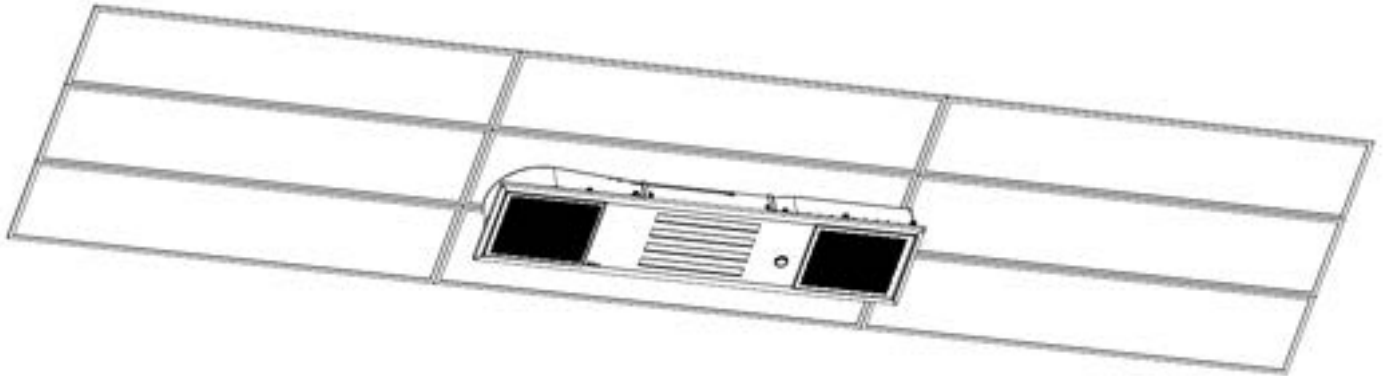

(A3)

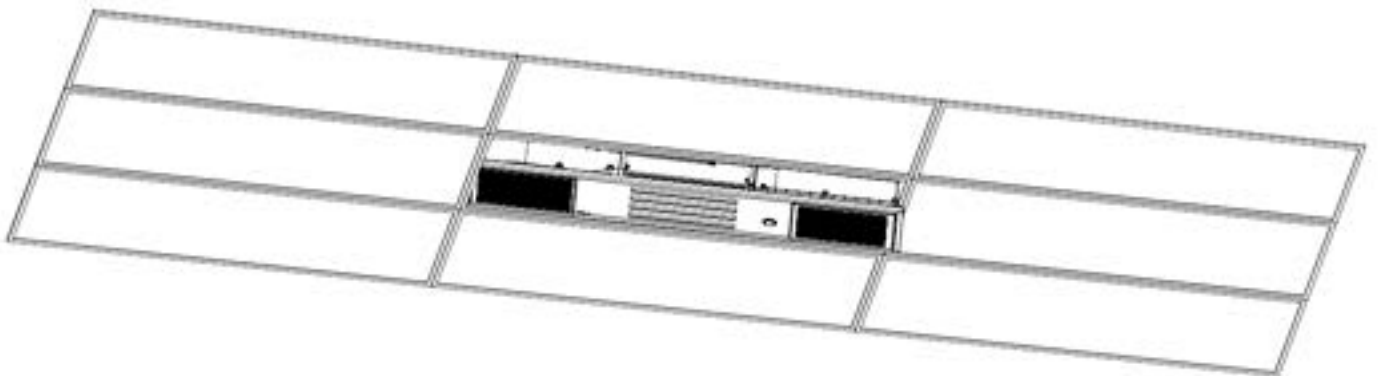

(A4)

- Take out the ceiling tile next to the PANEL to provide more space for safe operation. Suspend the safety wire to the ceiling. (A5)

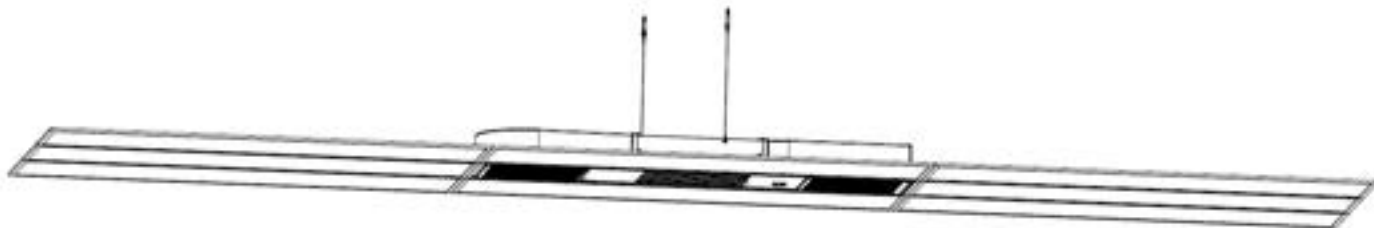

(A5)

- Reposition the other ceiling tile and complete the installation (A6).

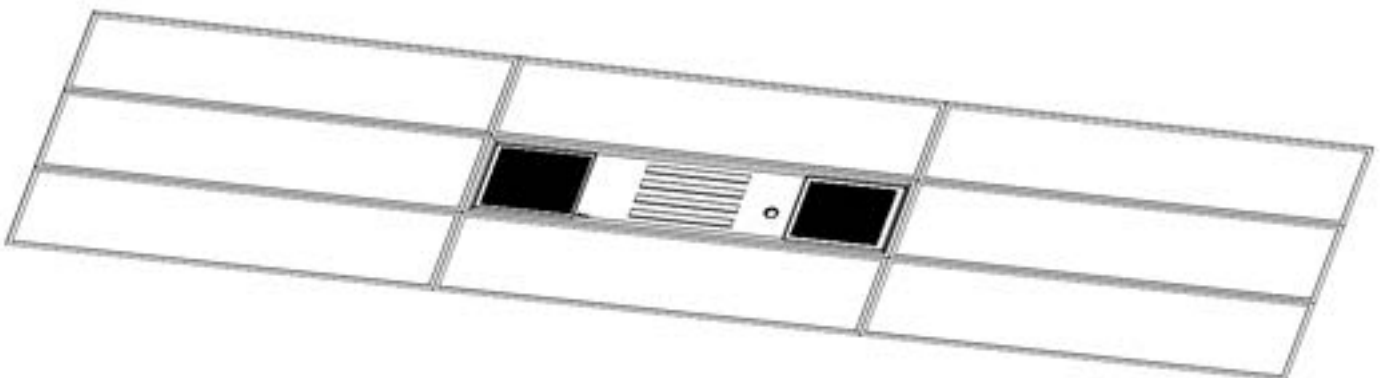

(A6)

- The plug drawing is shown below.

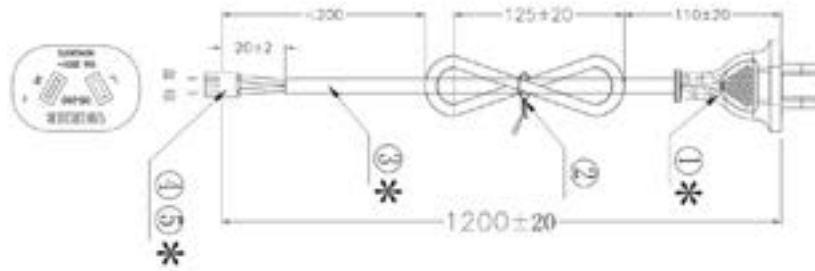

HEPA Installation Steps:

- Open the air vent. (B1)

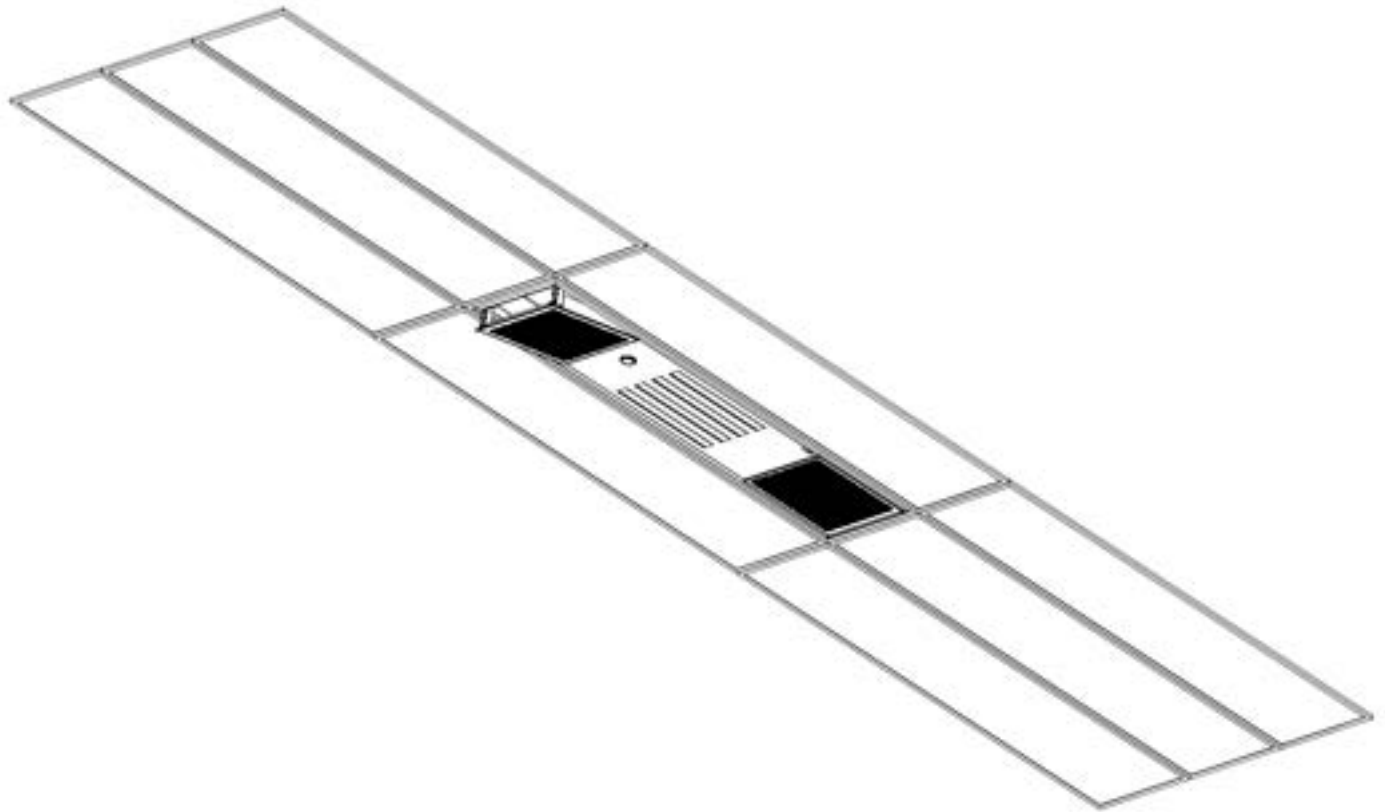

(B1)

- Remove the HEPA from the bag and confirm its direction based on the silk print prompt. (B2)

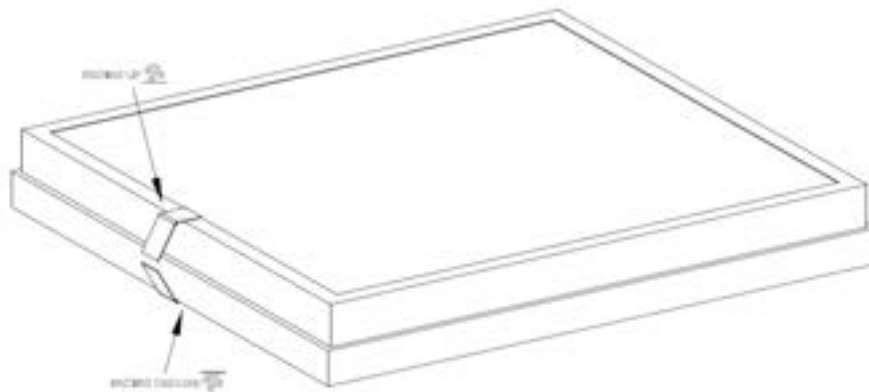

(B2)

- Insert the HEPA in the outlet according to the direction indicated. (B3)

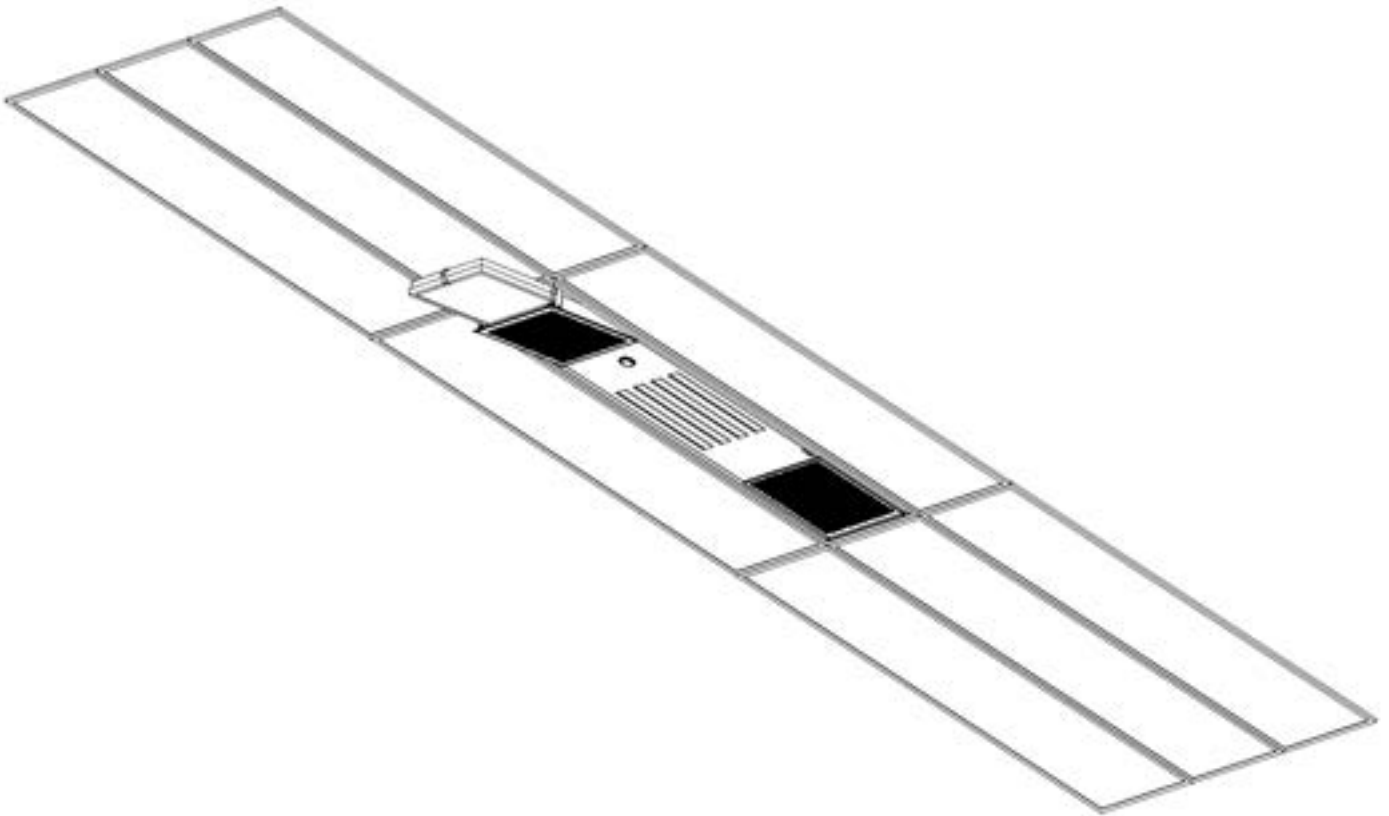

(B3)

- Complete the air outlet installation by pushing it up. (B4/B5)

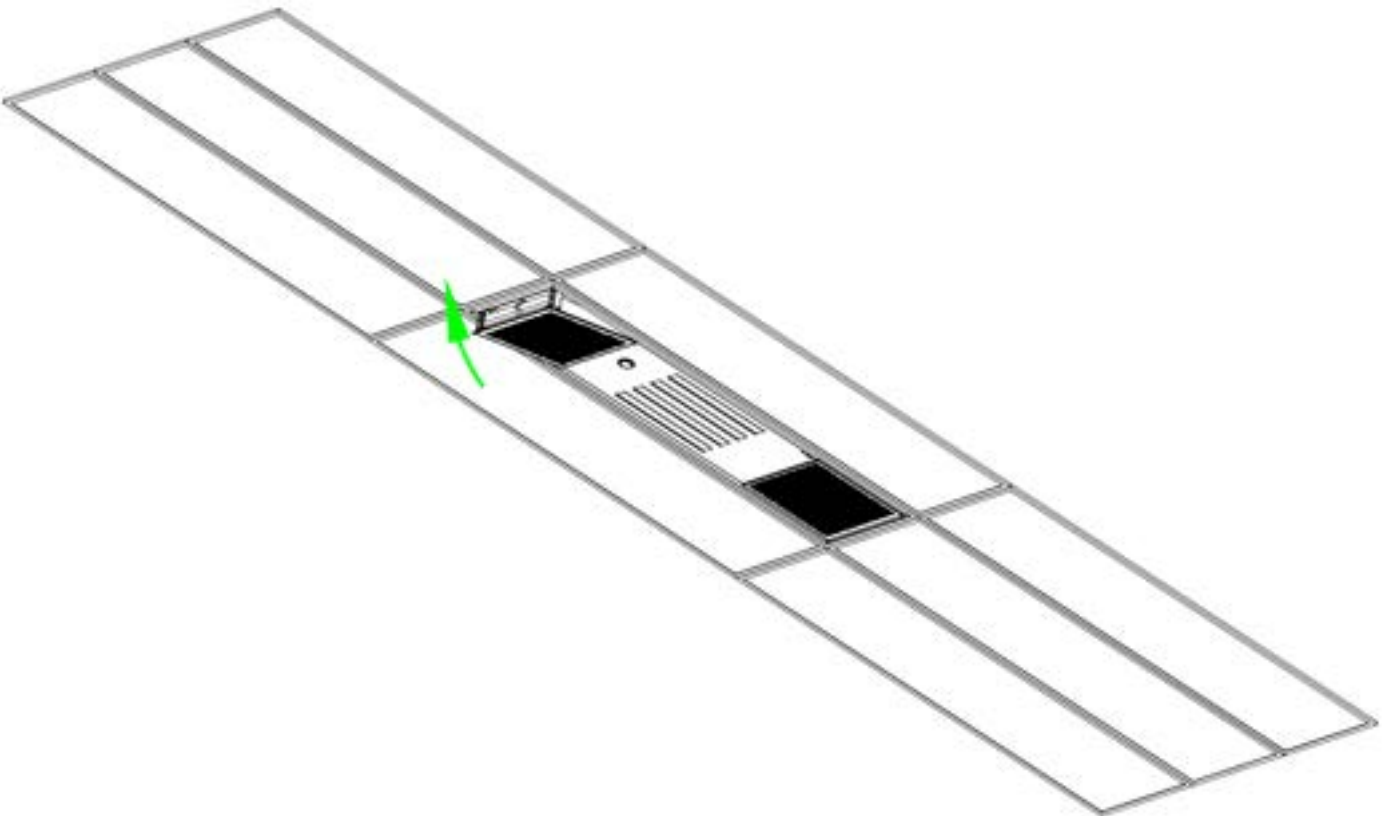

(B4)

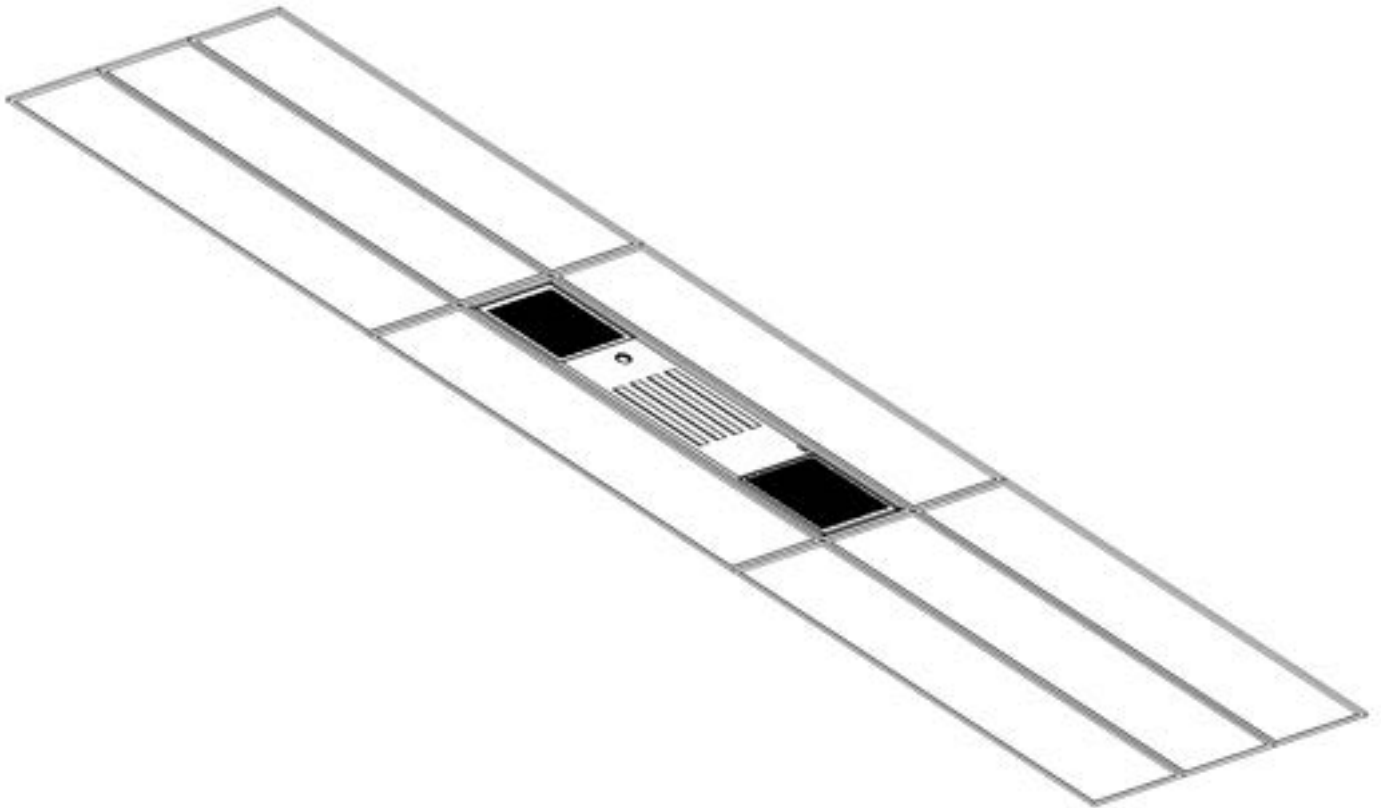

(B5)

UVC Module Replacement Steps:

- Turn off the power source before replacing the part.
- Remove the ceiling tile next to the Troffer. (C1)

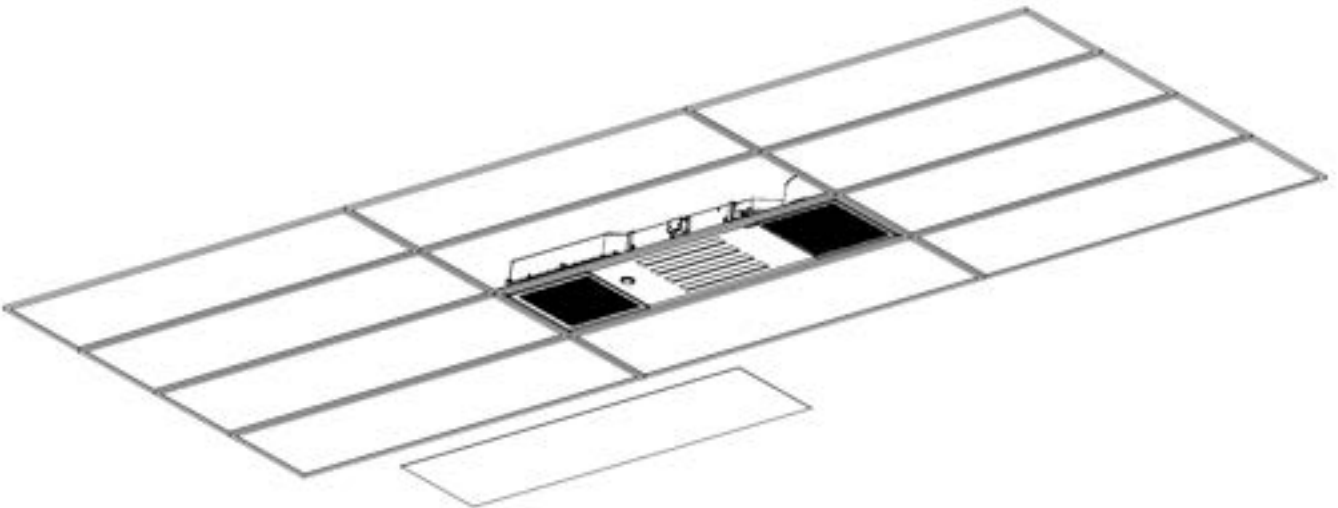

(C1)

- Locate and remove the UV module from the Troffer. (C2/C3)

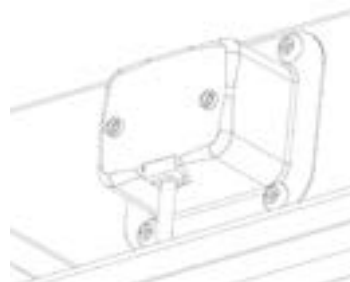

(C2)

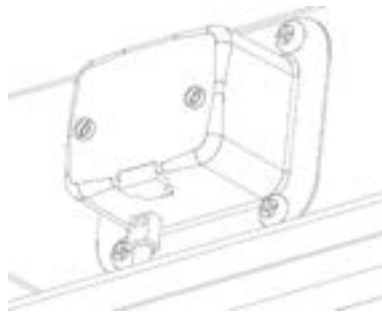

(C3)

- In order to complete the replacement, remove the four screws and install the new module.

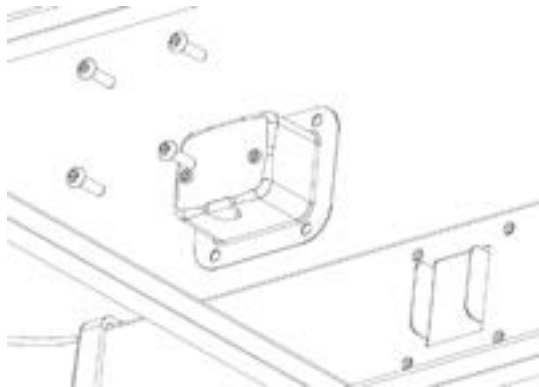

Remote Control Introduction:

Battery not included.

Logic of Remote Control (D1)

After Installation or replacement of new heap filter, the indicator is red, please press power button on the remote control or power off/power on again to start UVC and fan function, the indicator turns purple.

1. Power button:
On Status – Fan (max flow level 2) + UVC start working, indicator appears purple.
Off Status – Fan + UVC stop working, indicator off.
2. Fan Level Control Button:
Level 1-90m³/h. Level 2-170m³/h. indicator no change, users can feel it physically.
3. UVC Control Button:
Off status (manual off, fan remains working) – Indicator changes from purple to blue.
On status (manual open)-indicator changes from blue to purple
PS: UVC can't work solely.
4. The straight reception range of the remote control is 4m
5. Battery Specification:
Type: CR2032
Spec: 3V 210mAh
Battery Chemistry: Li-Mn (Lithium Manganese Dioxide battery)

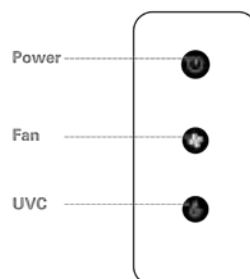

(D1)

PET Filter:

The filter needs to be cleaned with water every six months. (E1)



(E1)

General Cleaning

- Wear a protective face mask and gloves.
- Clear anyone with severe allergies out of the room.
- Turn off the unit.
- Wipe down the unit exterior including Air intake grill with a clean damp cloth.

Battery Warnings:

- Do not ingest battery – Chemical burn hazard
- The remote control supplied with this product do not contains a coin/button cell battery. Battery to per purchased separately as per the below specification.
Battery Specification:
Type: CR2032
Spec: 3V 210mAh
Battery Chemistry: Li-Mn (Lithium Manganese Dioxide battery)
- If the coin/button cell battery is swallowed it can cause severe internal burns in just 2 hours and can lead to death.
- Keep new and used battery away from children.
- If the battery compartment does not close securely, stop using the product and keep it away from Children
- If you think the battery might have been swallowed or placed inside any part of the body, seek immediate medical attention.

UVC Warnings

- This appliance contains a UVC emitter
- Inappropriate use of the troffer or damage to the housing may result in the escape of dangerous UVC radiation may, even in little doses, cause harm to the eyes and skin.
- Damaged troffer must not be operated.
- UV radiation is dangerous for the eyes and skin. Do not operate the UV-C emitter outside the appliance.

Replacement Schedules

- UVC module must be replaced after 15,000 hrs of operation. Please contact Pierlite for suitable replacement.
Product Code: AETUVCLED
The luminaire must be disconnected from the supply before replacing the UVC module.
- The HEPA filter must be replace after 6 months of operation. Please contact Pierlite for suitable replacement.
Product Code: AETHEPA

Others:

- If the external flexible cable or cord of this luminaire is damaged, it shall be exclusively replaced by the licensed electrician to avoid a hazard.
- The light source contained in this luminaire shall only be replaced licensed electrician.
- The troffer is not to be used by persons (including children) with reduced physical, sensory or mental capabilities, or lack of experience and knowledge, unless they have been given supervision or instruction
- children being supervised not to play with the troffer.
-The instructions for this troffer incorporating a functional earth state that the appliance incorporates an earth connection for functional purposes only.

FAQ – AETHER LED TROFFER

Section 1 – UVC

1. What does UVC stand for?

UVC refers to ultraviolet light with wavelengths between 200 – 280 nm.

2. How does UVC Led inactivate microorganisms?

UVC LED produces short-wavelength ultraviolet (ultraviolet C or UV-C) light to kill or inactivate microorganisms by destroying nucleic acids and disrupting their DNA, leaving them unable to perform vital cellular functions.

3. What is the UVC component of the Aether Troffer?

Seoul Violeds UV LED UV technology with peak emission wavelengths of 275nm is used in Aether Troffer. These Violeds UV-C LED's are also used by NASA aboard the International Space Station (ISS) to provide a healthy, germ-free environment for astronauts.

4. Is Seoul Violeds UV LED used in Aether Troffer effective against COVID-19?

Yes, Virucidal Activity Test by UV Irradiation was conducted by the KR Biotech Co Ltd Institute of Infectious Disease Control in Seoul Korea using the Seoul Viosys VSM+ UVC LED Chips. The sterilization test using UV radiation from Viosys VSM+ LED chips resulted in a 99.9999% virucidal inactivation against COVID-19 (SARS-CoV-2 Cell line Vero E6).

5. Is UVC radiation safe?

If not used or implemented properly, direct UVC exposure can have damaging effects in a variety of ways, such as eye and skin damage.

6. What are the safety precautions involved in the use of UVC LED in Aether Troffers?

The Seoul Violed UVC LED is concealed in air disinfection chamber integrated into a 1190mm x 290mm Aether LED troffer with no direct UVC radiation exposure to the room environment.

7. Has Aether Troffer been tested for UVC radiation leakage?

Aether Troffer fully complies to IEC 62471 standards of UVC hazard exposure limit for the skin and the eye.

8. Does the UVC LED used in Aether Troffer produce harmful Ozone?

The Aether troffer produces no harmful Ozone and is fully compliant and tested to meet Safe Work Australia standards.

9. How often does the UVC LED used in Aether Troffer need to be replaced?

We recommend the UVC module to be replaced after 15,000 hrs of operation. Pierlite provides a 2-year warranty on UV-C led module or Maximum 15,000 hrs.

Section 2 – HEPA Filter

1. What are HEPA filters and how do they work?

HEPA stands for High-Efficiency Particulate Air.

HEPA Filter works by forcing incoming air through a very fine mesh that traps all the harmful particles

2. What type of HEPA filter does Aether Troffer use?

Aether troffers use H13 HEPA filters, which are the highest tier of HEPA and are considered medical grade.

HEPA H13 filters can trap up to 99.95% of particles with a minimum size of 0.1 microns in diameter

3. How does Germagic technology work on H13 HEPA filters?

The Germagic HEPA filter releases Prolonged Oxidizing Particles continuously and oxidizes them through contact killing, release killing and antibacterial adhesion.

4. Is H13 HEPA filter used in Aether Troffer effective against COVID-19?

Microbac Laboratories Inc, USA conducted a Hard Surface Efficacy test on HEPA filter used in Aether Troffer. Tests against COVID-19 (SARS-CoV-2 Cell line Vero E6) showed that the H13 HEPA filter is highly effective on the surface.

5. When should a HEPA filter be replaced?

It is recommended that the HEPA filter is replaced every six months.

6. During HEPA filter replacement, what precautions should be taken?

When replacing HEPA filters, personal protective equipment (PPE), typically gloves and a mask, is recommended.

Section 3 – Aether Troffer

1. What is the principle behind the Aether Troffer?

Aether Troffer utilizes a 3-step air purification system including DC motor with filter screen, UV-C LED disinfection and HEPA filter that traps airborne particles, inactivates microorganisms, and eliminates viruses, bacteria, VOCs and odours.

Aether troffer also provides exception lighting characterises.

2. Has Aether undergone any virucidal research and testing?

There have been two major Virucidal studies conducted on Aether troffer.

First, the Biotec GmbH lab in Germany conducted an independent study on airborne virus inactivation rates with the Aether UVC Air Purifier Troffer using MS2 Surrogate virus, with 99.995% inactivation rate.

Secondly, clinical validation and reduction of viral load in the air stream were performed by the Guangdong Detection Centre of Microbiology in China using the TGA approved Human Corona Virus HCoV-229E Host Cell Huh-7 with a 99.98% inactivation rate.

Separate virucidal testing has been performed on HEPA filter and UVC LED

3. Does Aether require TGA Australia approval?

Air and UV purifiers/sanitiser are considered excluded goods under the Therapeutic Goods (Excluded Goods) Determination 2018, schedule 1, item 12 - sanitation, environmental control and environmental detoxification equipment (provided it is not intended for disinfecting medical devices, if they are intended to disinfect medical devices then they may fall under a IIb classification)

4. Where is Aether designed and manufactured?

Aether's design has been registered with IP Australia.

The product is manufactured in China.

5. What is the time it takes for Aether troffer to reduce the germ count?

The testing on Aether troffer showed that total germs in a defined test room (36.5 m³) decreased by more than 40% within an hour after start-up.

6. Does the Aether troffer comply with the Cyanosis index?

Yes, Aether uses Samsung's 2835 CRI 90 Chip. The COI (Cyanosis Observer Index) measures 1.713

7. Is the Aether troffer dimmable?

Aether uses the DALI driver. The troffer can be used with a DALI compliant control system.

8. Aether troffers come in what sizes?

There is currently only one size L1190 X W290 X H98.5.

However, Surface mount and suspended options are available.

9. What is the default wattage/lumen setting? How can the lumen setting be changed?

The default setting is 28w/2800lumens. Lumens output and wattage can be changed using the NFC Programming Interface. The process can be done in the Padstow factory or on site.

10. What is the Section J6 NCC implications for lighting design with Aether?

For National Construction Code Section J6 assessment, the load of the fan and UV-C leds are not to be included in Illumination power density (IPD) calculations. The IPD of Aether is a respectable 100lm/w and this includes the DALI driver.

The use of a DALI driver will allow an additional adjustment factor under NCC J6 rules.

To avoid confusion, the IES files only consists of lighting load.

11. How does Aether integrate into a space with other troffers?

The optics of Aether is designed to suit standard luminaire spacing.

Aether is easy to integrate with other troffers for commercial sites. However, lighting design and analysis is recommended.

12. What is the recommended spacing for Aether troffer?

Each Aether treats a 20.4m² room effectively.

13. What is the Clean Air Delivery Rate (CADR) for Aether Troffer?

The Clean Air Delivery Rate (CADR) for Aether with HEPA filter is 170m³/h or 100 CFM and produces 47.22 liters of clean air every second. This data can be integrated into the site's existing HVAC loading.

14. What is the Air Changes Per Hour (ACPH) for Aether?

ACPH for Aether is 8.55 tested for 23.4m³ space. This data can be integrated into the site's existing HVAC loading.

15. Does Aether improve CO2 levels?

The CO2 levels will not be improved by using Aether.

Aether purifies the air within confined spaces. CO2 levels can be improved by bringing outside air into a room.

16. What is the purpose of an infrared remote control?

The remote control could be used to turn off the UVC LED and to reduce the motor speed or turn it off completely.

17. If the light is turned off and then turned back on the next day, will the fan and UV-C come on automatically?

Yes

18. If the light is turned off and then turned back on the next day, will the previous settings be active when switched on - Memory function.

No, general lighting + UVLED + Motor will always turn on upon 240v supply.

19. Can light be turned off and have fan/UV-C remain operational.

No, remote is only functional with UVLED and motor.

20. What's the lifetime of DC motor?

30,000 hrs.

21. What effect does air purification have when the motor is running at a low speed?

Aether allows you to set two motor speeds. The low-speed version will reduce air purification capability by half.

Low Speed CADR : 90m³/h.

High Speed CADR: 170m³/h

22. To what standards does Aether adhere?

Aether complies to various Luminaire and Air purification Australian standards.

23. What is the warranty on Aether Troffers?

- 5-year warranty for UV device housing, mechanical, white light-emitting components, ballast, and driver or Maximum 50,000 hrs
- 3-year warranty on UV device fans and other electrical components or Maximum 30,000 hrs
- 2-year warranty on UV-C led or Maximum 15,000 hrs
- 6 months warranty on HEPA filter