

## INSTALLATION / WARRANTY INSTRUCTIONS

PRODUCT BRAND: PIERLITE

PRODUCT NAME: MML 250W

PRODUCT CODE: MML250LSCSA, MML250LSCSS, MML250LSAA, MML250LSAS

Issue Date: 03/11/2022

Please read these installation instructions carefully before installing or maintaining this equipment. The product is designed for installation and maintenance in accordance with relevant Australian standards (AS/NZ3000), by an authorized and licensed electrician. The installation instructions were correct at the time of print. To reflect changes in technology and Australian and New Zealand standards; Pierlite reserves the right to amend the instructions without notice. Updated guidelines can be found on relevant brand web site.



### 1. PRODUCT SPECIFICATION:

Type of protection	Class I luminaire
Type of protection	IP66
IK rating	IK08
IC Rating	N/A
Nominal voltage	220 - 240VAC
Nominal frequency	50/60 Hz
Number of wattages per fitting	4 per fitting refer 3 selections
Available wattages	Refer to section 3
Power factor	>0.9
Surge protection rating	Input Surge Protection: 10kV line-line, 10kV line-earth
Inrush current	Cold start 65A (twidth=240 s measured at 50% Ipeak) at 230VAC
Earth leakage	<0.7mA
Rated operating ambient temperature	0 to +50°C
LED lifetime	Rated 54,000 hours (L70/B10) +50°C Calculated >107000 hours (L70/B10) @ +50°C Rated 32,000hours (L90/B10) +50°C Calculated 32,000 hours (L90/B10) @ +50°C
Emergency battery design life	N/A
Colour temperature	3000K/4000K/5000K(colour select) and Amber(single colour)
Colour rendering index (CRI)	>80(exclude Amber)
LED control gear	Lumen select
Available in emergency	N/A
Emergency battery technology	N/A
Electrical connection	6.0mm diameter terminal block
Cable entry	1x 20mm – cable diameter size 8mm – 12.5mm +/- 0.5mm
Installation type	Surface mounted via Trunnion arm
Dimensions (LxWxH)	Refer to table in section 4
Net weight of luminaire	Refer to table in section 4
Warranty	Luminaire: 5 years
Suitability	Outdoor only
Suitable for rough service	Yes
Replacement Light Source	No

### 2. CONSUMABLES

Description	QTY Required Per Fitting	Brand	Component Part Number	Dimensions (LxWxH) mm
N/A	N/A	N/A	N/A	N/A

### 3. LUMEN SELECT AND COLOUR SELECT TABLE (contractor selectable output)

Pierlite's lumen select products allows all licensed electricians to purchase one luminaire that can be set as multiple fixed wattages/fixed lumen outputs. By offering this capability within one fitting, it provides the following benefits

- One fitting multiple fixed outputs
- Less stocked items
- Easy to change settings
- IES files available for all available for wattages shown in the above table
- No control system or software required to change fixed output

The lumen output can be altered by changing the driver dip switches from the factory default setting to the driver milli-amps as specified in the table. Dip switches are located next to the terminal block inside the junction box of the floodlight.

The color output can be altered by changing the dip switches from the factory default setting as specified in the table (Not include PC Amber type). Dip switches are located next to the terminal block inside the junction box of the floodlight.

Product Code#	Power (W)	Emergency Wattage (W)	Line Current (A)	Lumen Output (Lm)	Dip Switch Settings Refer section 5			CCT (K)	Optics
					1	2	3		
MML250LSCSA	250(default)	N/A	1.07	32900	Off	Off	Off	3000K	Asymmetrical
	200		0.86	26700	On	Off	Off		
	150		0.66	21500	Off	On	Off		
	100		0.47	14900	Off	Off	On		
	250(default)	N/A	1.07	35500	Off	Off	Off	4000K (Default)	
	200		0.86	28600	On	Off	Off		
	150		0.66	22500	Off	On	Off		
	100		0.47	15400	Off	Off	On		
	250(default)	N/A	1.07	34000	Off	Off	Off	5000K	
	200		0.86	27900	On	Off	Off		
	150		0.66	22200	Off	On	Off		
	100		0.47	15300	Off	Off	On		
MML250LSCSS	250(default)	N/A	1.07	33600	Off	Off	Off	3000K	Symmetrical
	200		0.86	27500	On	Off	Off		
	150		0.66	21800	Off	On	Off		
	100		0.47	15000	Off	Off	On		
	250(default)	N/A	1.07	36200	Off	Off	Off	4000K (Default)	
	200		0.86	29300	On	Off	Off		
	150		0.66	23100	Off	On	Off		
	100		0.47	15500	Off	Off	On		
	250(default)	N/A	1.07	34800	Off	Off	Off	5000K	
	200		0.86	28500	On	Off	Off		
	150		0.66	22800	Off	On	Off		
	100		0.47	15600	Off	Off	On		
MML250LSAA	250(default)	N/A	1.07	20800	Off	Off	Off	1850K	Asymmetrical
	200		0.86	16700	On	Off	Off		
	150		0.66	13700	Off	On	Off		
	100		0.47	9600	Off	Off	On		
MML250LSAS	250(default)	N/A	1.07	21000	Off	Off	Off	1850K	Symmetrical
	200		0.86	16900	On	Off	Off		
	150		0.66	13900	Off	On	Off		
	100		0.47	9800	Off	Off	On		

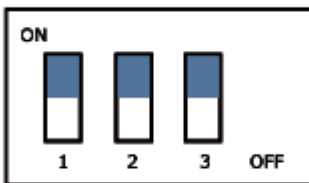

Lumen Select switch

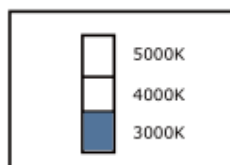

CCT Select switch  
(Not include PC Amber type)

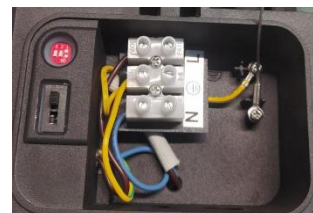

**Note:** Make sure to disconnect power before changing a DIP switch on the luminaries. Setting the DIP switches according to the above ONLY. All other settings may affect the luminaries' performance. After setting, secure the screws fastened to junction box cover.

## 4. LINE DIAGRAMS AND DIMENSIONS

Length (mm)	Width (mm)	Height (mm)	Weight in (kg)	Maximum Projected Area
523	342.3	184.9	6.2	0.17M <sup>2</sup>

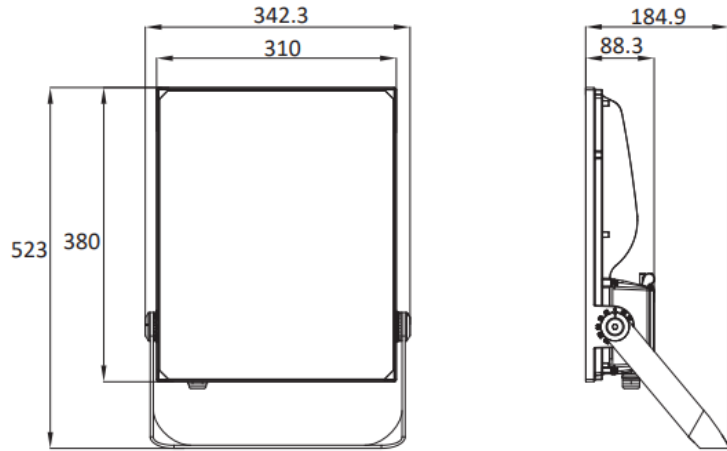

Maximum projected area: 0.17m<sup>2</sup>

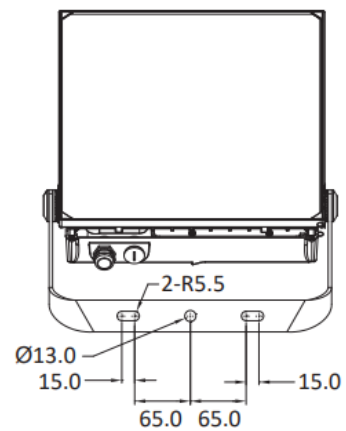

Trunnion arm dimension drawing with all mounting holes

**5. INSTALLATION / GENERAL:** Installation of the product is to be completed by an authorized and licensed electrician, in accordance with these instructions, relevant Australia standards and local regulations (where applicable). Termination of product wiring, together with the installation of the product must be in a manner and orientation that maintains the integrity of the designated IP rating of the product for electronic control equipment (when supplied) DO NOT MEGGER between A and N.

### Installation:

1. Isolate the supply circuit as per the Australian standard and your SWMS/site requirement.
2. Mount trunnion arm on substrate.
3. Remove screws on control gear cover.
4. Install cable through cable gland then connect to supply terminal block
5. Connect electrical cables as specified by Australian and New Zealand wiring standards(AS3000), it must be installed by a licensed electrician. Ensure the earth is connected.
  - Luminaire electrical connections
    - a. Connect earth into E terminal
    - b. Connect Neutral into N terminal
    - c. Connect active into A terminal
6. Select the CCT and wattage/lumen output by changing the dip switches, please refer to section 3 of this installation sheet.
7. Reinstall the control gear cover making sure all screws are installed this will ensure the IP66 rating is provided.
8. Aim floodlight to the desired orientation
9. Ensure the IP rating of the installation is equal to that of the tested IP rating of the fitting.
10. Test fitting as per the relevant Australian standard and as per your SWMS

### Installation Orientation

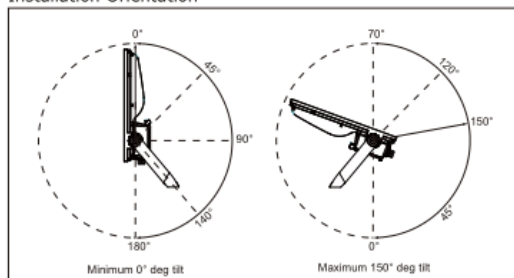

**IMPORTANT** - the product must be maintained and operated in accordance with the manufacturer's instructions, failure to do so may damage the product and services. It is strongly recommended that this important note be communicated to the owner and or operator of the installation at the time of site commissioning. Good practice does not recommend the 24/7 use of products without the application of suitable switch cycle intervals. Furthermore, with the omission of nominated survival curves and or recommended operating hours, product design expectations provide for a continual daily usage of 6 hours for residential applications and a continual daily usage of 12 hours for commercial and industrial applications. All products must be thoroughly cleaned on a regular basis at intervals that reflect in the installation environment, ensuring the optical performance, together with the electrical, mechanical, and structural integrity as designed, is maintained throughout the service life of the product.

**APPROVALS:** The RCM marking of this product applies to AS/NZS CISPR15 (EMC) "Limits and methods of measurement of radio disturbance characteristics of electrical lighting and similar equipment". This product is designed to conform to AS/NZS60598 "Luminaires, general requirements and tests".



**STORAGE:** Prior to installation products are to be stored in cool and dry conditions.

**APPLICATION:** The installation application and orientation of the product is designed in accordance with the nominated product IP rating, class designation and these installation installations. Installation environments outside these conditions are not recommended.

**MAINTENANCE:**

(a) The supply must be isolated before opening or accessing the luminaire. Product maintenance is IMPORTANT and is critical to the products designed performance. The product is to be maintained in accordance with the manufacturer's instructions. For the latest product maintenance guides please go to relevant brand web site. Pierlite is not responsible for any product not maintained in accordance with the recommended procedure or intervals.

(b) **Lamps (where provided):** The product is designed with the supplied (LEDs) / LAMP/s and it is strongly recommended that any LAMP / (LEDs) changes (if any) be made in accordance with the type, colour and brand supplied. For recommended LAMP / LED maintenance or operating guides (inclusive of recommended product switch cycles and mandatory run-in procedures for HID and Fluorescent lamps when used with dimming circuits), Pierlite recommends the application of the lamp manufacturer's operating guidelines, which can be found on manufacturer's website. Pierlite is not responsible for the product performance of alternative lamp/s used. As a member of FluroCycle, we encourage recycling of lamps and components.

(c) **Battery (where provided):** The battery is designed with a rated average battery design life in standby mode and is supported with a standard warranty (refer to product specifications for details); conditional of the product being maintained and operated in accordance with the manufacturer's guidelines and tested in accordance with AS/NZS2293. For guidelines see product installation instructions or visit the relevant brand web site.

(d) **For products supplied with glass visors or covers,** do not operate the product with a damaged visor or cover; it is recommended the product be turned off, area surrounding the product vacated, and the damaged glass replaced by a professional installer immediately.

(e) **Cables or chords,** If Any external cable or cord of the X or Y type luminaire is damaged, it shall be replaced by a by a qualified person or manufactures service agent.

For Z type attachments to luminaire, cord cannot be replaced if damaged, the luminaire shall be removed from service.

Flex cord types.

- X: A specially prepared flexible cable or cord, may also include a part of the luminaire and only available from manufacture.
- Y: Attachment may be used either with ordinary or special flexible cable or cord.
- Z: Attachment of cable or cord that cannot be replaced without damage to luminaire

**WARRANTY INSTRUCTIONS:** For the purpose of warranty claims (if any) the following instructions apply:

**Warranty period** - The above components are provided with a warranty (refer to product specifications for details) against manufacturing defects or failure to perform to specifications for products installed by an authorised installer in accordance with the manufacturer's installation instructions and which have not been subject to incorrect operation or maintenance, unauthorised modification or damage arising from any intervening cause.

**Warranty reference** - The warranty reference date commences from the date of purchase.

**Warranty point of contact** – Pierlite, 96 Gow Street Padstow NSW 2211, phone T 1300 799 300 contact – Pierlite After Sales Support.

**Warranty claim procedure** – For the purpose of making a claim the customer must:

1. Contact the "point of contact" above and upon provision of proof of purchase the customer will receive a goods return advice (GRA) number.
2. At the customer's expense, collect and return the goods to the "point of contact" with the issued GRA number.
3. Upon receipt of the goods, Pierlite will review the claim and if found to be accepted, Pierlite will return a replacement product to the customer to install at the customer's expense. Alternatively, if the claim is rejected, the customer may request the return of the goods at their expense.

**Consumer Contracts** - The benefits to the customer given by the Pierlite warranty are in addition to other rights and remedies of the customer if the goods are the subject of a Consumer Contract under the Australian Consumer Law. In that event the following statement is required to be brought to the Consumer's attention: - *Our goods come with guarantees that cannot be excluded under the Australian Consumer Law. You are entitled to a replacement or refund for a major failure and for compensation for any other reasonably foreseeable loss or damage. You are also entitled to have the goods repaired or replaced if the goods fail to be of acceptable quality and the failure does not amount to a major failure.*

**Limitation of Liability** – if the goods are not purchased by the customer under a Consumer Contract within the Australian Consumer Law then but not otherwise;- (a) the Company is not liable in tort for any loss or damage suffered by the customer or by any third party; and (b) in no circumstances is Pierlite liable to the customer or to any third party for any loss of profits, loss of anticipated savings, economic loss or interruption of business or for any indirect or consequential loss (Consequential Loss).

**Terms of Sale** – these warranty provisions are in substitution for any inconsistent provisions in the Pierlite Terms and Conditions of Sale in so far as they apply to the warranty components.